

DEPARTMENT OF PERMITTING, ENVIRONMENT, AND REGULATORY
AFFAIRS (PERA)
BOARD AND CODE ADMINISTRATION DIVISION
NOTICE OF ACCEPTANCE (NOA)

MIAMI-DADE COUNTY
PRODUCT CONTROL SECTION
11805 SW 26 Street, Room 208
Miami, Florida 33175-2474
T (786) 315-2590 F (786) 315-2599
www.miamidade.gov/pera/

Solar Coil, LLC
1257 Flushing Avenue
Clearwater, FL 33764

SCOPE:

This NOA is being issued under the applicable rules and regulations governing the use of construction materials. The documentation submitted has been reviewed and accepted by Miami-Dade County PERA - Product Control Section to be used in Miami Dade County and other areas where allowed by the Authority Having Jurisdiction (AHJ).

This NOA shall not be valid after the expiration date stated below. The Miami-Dade County Product Control Section (In Miami Dade County) and/or the AHJ (in areas other than Miami Dade County) reserve the right to have this product or material tested for quality assurance purposes. If this product or material fails to perform in the accepted manner, the manufacturer will incur the expense of such testing and the AHJ may immediately revoke, modify, or suspend the use of such product or material within their jurisdiction. PERA reserves the right to revoke this acceptance, if it is determined by Miami-Dade County Product Control Section that this product or material fails to meet the requirements of the applicable building code. This product is approved as described herein, and has been designed to comply with the Florida Building Code, including the High Velocity Hurricane Zone.

DESCRIPTION: Model SC092809BK Plastic Passive Solar Water Heater

APPROVAL DOCUMENT: Drawing No. SC_0001, titled "SC092809BK Passive Solar Collector", sheets 1 through 3 of 3, dated 05/31/2011, with last revision dated 12/07/2011, prepared by Solar Coil, LLC, signed and sealed by Paul E. Winter, P.E., bearing the Miami-Dade County Product Control approval stamp with the Notice of Acceptance number and approval date by the Miami-Dade County Product Control Section.

MISSILE IMPACT RATING: Large and Small Missile Impact Resistant

LABELING: Each unit shall bear a permanent label with the manufacturer's name or logo, city, state, model/series, and following statement: "Miami-Dade County Product Control Approved", unless otherwise noted herein.

RENEWAL of this NOA shall be considered after a renewal application has been filed and there has been no change in the applicable building code negatively affecting the performance of this product.

TERMINATION of this NOA will occur after the expiration date or if there has been a revision or change in the materials, use, and/or manufacture of the product or process. Misuse of this NOA as an endorsement of any product, for sales, advertising or any other purposes shall automatically terminate this NOA. Failure to comply with any section of this NOA shall be cause for termination and removal of NOA.

ADVERTISEMENT: The NOA number preceded by the words Miami-Dade County, Florida, and followed by the expiration date may be displayed in advertising literature. If any portion of the NOA is displayed, then it shall be done in its entirety.

INSPECTION: A copy of this entire NOA shall be provided to the user by the manufacturer or its distributors and shall be available for inspection at the job site at the request of the Building Official. This NOA consists of this page 1 and evidence page E-1, as well as approval document mentioned above. The submitted documentation was reviewed by Carlos M. Utrera, P.E.



[Signature]
06/07/2012

NOA No. 11-1012.01
Expiration Date: June 14, 2017
Approval Date: June 14, 2012
Page 1

NOTICE OF ACCEPTANCE: EVIDENCE SUBMITTED

A. DRAWINGS

1. Drawing No. **SC_0001**, titled "SC092809BK Passive Solar Collector", sheets 1 through 3 of 3, dated 05/31/2011, with last revision dated 12/07/2011, prepared by Solar Coil, LLC, signed and sealed by Paul E. Winter, P.E.

B. TESTS

1. Test reports on: 1) Uniform Static Air Pressure Test, Loading per FBC, TAS 202-94
2) Large Missile Impact Test per FBC, TAS 201-94
3) Cyclic Wind Pressure Loading per FBC, TAS 203-94
along with installation diagram of Series SC 092809BK Passive Solar Water Heaters, prepared by Fenestration Testing Laboratory, Inc., Test Report No. **6547**, dated 07/27/2011, signed and sealed by Marlin D. Brinson, P.E.
2. Test report on Wind Driven Rain Resistance Test per FBC, TAS 100-95 of a Series SC092809BK Passive Solar Water Heater, prepared by Fenestration Testing Laboratory, Inc., Test Report No. **6585**, dated 08/26/2011, signed by Marlin D. Brinson, P.E.

C. CALCULATIONS

1. Anchor calculations complying with 2007 FBC, prepared by Paul E. Winter, P.E., dated 09/21/2011, signed and sealed by Paul E. Winter, P.E.

D. QUALITY ASSURANCE

1. Miami-Dade Department of Permitting, Environment, and Regulatory Affairs (PERA)

E. MATERIAL CERTIFICATIONS

1. Notice of Acceptance No. 10-0329.03 issued to Sheffield Plastics, Inc., for their "Makrolon Polycarbonate Sheets", approved on 07/07/2010 and expiring on 08/27/2012.
2. ICC Evaluation Service Report ESR-2072 issued to Bayer Material Science, LLC, for their Bayseal CC Spray Applied Polyurethane Foam Insulation, reissued on 09/01/2011.

F. STATEMENTS

1. Statement letter of code conformance to 2007 and 2010 FBC and no financial interest, issued by Paul E. Winter, P.E., dated 03/28/2012, signed and sealed by Paul E. Winter, P.E.



06/07/2012

Carlos M. Utrera, P.E.
Product Control Examiner
NOA No. 11-1012.01
Expiration Date: June 14, 2017
Approval Date: June 14, 2012

SOLAR COIL, LLC

(PASSIVE SOLAR WATER HEATER)

INSTALLATION ANCHORAGE DETAILS

GENERAL NOTES:

1. THE SC092809BK IS DESIGNED AND TESTED IN ACCORDANCE WITH THE FLORIDA BUILDING CODE (FBC) AND TEST PROTOCOLS TAS-201 (IMPACT), TAS-202 (UNIFORM STATIC PRESSURE), AND TAS 203 (CYCLIC FATIGUE). THE SC092809BK HAS BEEN TESTED IN ACCORDANCE WITH TAS100(A)-95 (WIND DRIVEN RAIN).
2. IN AREAS WHERE WIND-BORNE DEBRIS PROTECTION REQUIREMENTS EXIST, USE OF AN APPROVED IMPACT PROTECTIVE SYSTEM IS NOT REQUIRED.
- 3.0. FRAME & SPACER: POLYCARBONATE BACK COVER & SPACER
- 3.1 MATERIAL: 0.375" MAKROLON GP POLYCARBONATE MEETING MIAMI DADE COUNTY REQUIREMENTS.
- 3.1 SMOKE DENSITY RATING ACCORDING TO ASTM D2843 TESTING IS 24.3 WHICH IS LESS THAN 75 REQUIRED BY SECTION 2612 OF THE FLORIDA BUILDING CODE AND MIAMI-DADE REQUIREMENTS.
- 3.2 RATE OF BURNING CLASS IS CC1 ACCORDING TO ASTM D635 WHICH MEETS SECTION 2612 OF THE FLORIDA BUILDING CODE AND MIAMI-DADE REQUIREMENTS.
- 3.3 SELF IGNITION TEMPERATURE IS 1040 DEG. F ACCORDING TO ASTM D1929 WHICH IS GREATER THAN 650 DEG. F REQUIRED BY SECTION 2612 OF THE FLORIDA BUILDING CODE AND MIAMI-DADE REQUIREMENTS.
4. GLAZING:
 - 4.1. MATERIAL: 0.375" THICK MAKROLON SL POLYCARBONATE GLAZING MEETING MIAMI-DADE COUNTY REQUIREMENTS.
 - 4.2. SMOKE DENSITY RATING ACCORDING TO ASTM D2843 TESTING IS 57.7 WHICH IS LESS THAN 75 REQUIRED BY SECTION 2612 OF THE FLORIDA BUILDING CODE AND MIAMI-DADE REQUIREMENTS.
 - 4.3. RATE OF BURNING CLASS IS CC1 ACCORDING TO ASTM D635 WHICH MEETS SECTION 2612 OF THE FLORIDA BUILDING CODE AND MIAMI-DADE REQUIREMENTS.
 - 4.4. SELF IGNITION TEMPERATURE IS 1022 DEG. F ACCORDING TO ASTM D1929 WHICH IS GREATER THAN 650 DEG. F REQUIRED BY SECTION 2612 OF THE FLORIDA BUILDING CODE AND MIAMI-DADE REQUIREMENTS.
5. INSULATION:
 - 5.1. MATERIAL: BAY SEAL CC, CLOSED CELL POLYURETHANE FOAM BRAND INSULATION.
 - 5.2. FLAME SPREAD INDEX ACCORDING TO ASTM E84 TESTING IS LESS THAN 75 REQUIRED BY SECTION 2612 OF THE FLORIDA BUILDING CODE AND MIAMI-DADE REQUIREMENTS.
 - 5.3. SMOKE DENSITY INDEX ACCORDING TO ASTM E84 TESTING IS IS LESS THAN 450 REQUIRED BY SECTION 2612 OF THE FLORIDA BUILDING CODE AND MIAMI-DADE REQUIREMENTS.

INSTALLATION NOTES:

1. ONE (1) INSTALLATION ANCHOR IS REQUIRED AT EACH ANCHOR LOCATION SHOWN.
2. THE NUMBER OF INSTALLATION ANCHORS DEPICTED IS THE MINIMUM NUMBER OF ANCHORS TO BE USED FOR PRODUCT INSTALLATION AT THE TESTED SIZE SHOWN.
3. ANCHORS ARE TO MATCH TYPE, SIZE, AND SPACING OF THOSE SHOWN HEREIN.
4. FOR INSTALLATION INTO ROOF DECKING, USE 1/4" SNAPTGGLE 6" IN LENGTH TO ACHIEVE FULL ENGAGEMENT INTO ROOF DECKING, WHERE CONFLICT OCCURS BETWEEN FASTENER LOCATION AND EXISTING WOOD TRUSSES ANCHOR DIRECTELY WITH 5/16" X 6" HOT DIPPED GALVANIZED LAG BOLTS.
5. ALL ROOFING MATERIALS SHALL COMPLY WITH CHAPTER 15 OF THE FLORIDA BUILDING CODE. 4" MINIMUM DISTANCE FROM BASE LIP TO ROOF SURFACE FOR SHINGLE OR BUR W/O INSULATION.

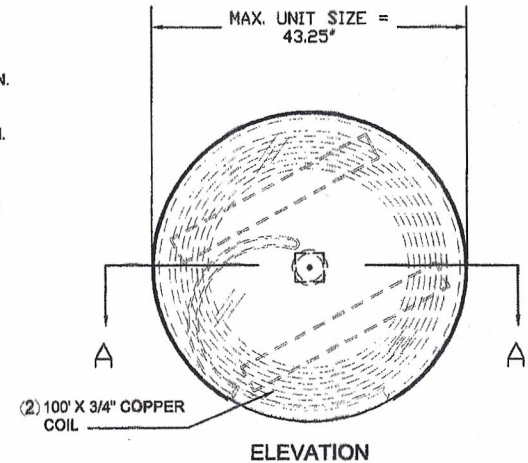

TABLE OF CONTENTS		
SHEET	REV.	SHEET DESCRIPTION
1	---	GENERAL NOTES & TABLE OF CONTENTS
2	---	ANCHOR DETAILS & BOM
3	---	PIPING DIAGRAM & WORKING PRESSURES

DESIGN PRESSURE RATING (PSF)	IMPACT RATING
±70.0	LARGE MISSILE IMPACT

Approved as complying with the Florida Building Code
 Date 06/14/2012
 NOAs 11-1017.01
 Miami Dade Product Control
 By [Signature]

REV	PER MIAMI DADE COMMENTS	DATE
SYM	REVISION	
		12/07/11

Paul Winter
 (12/07/11)
 PAUL E. WINTER, P.E.
 Florida P. E. No. 22693

SOLAR COIL, LLC			
1237 FLUSHING AVENUE CLEARWATER, FL 33764			
TITLE: SC092809BK PASSIVE SOLAR COLLECTOR GENERAL NOTES AND TABLE OF CONTENTS			
DRN:	RM:	DATE:	05/31/11
SCALE:	N.T.S.	DWG. NO.:	SC_0001
REV:	A	SHEET:	1 OF 3

ITEM NO.	DESCRIPTION	QTY	MANUFACTURER
1	MAKROLON SL POLYCARBONATE GLAZING COVER, 0.375"	1	SHEFFIELD PLASTICS
2	100' X 34" COPPER COIL	1	GORMAN SUPPLY
3	RIGID FOAM INSULATION	AS REQD.	BAYER MATL. SCIENCE
4	POLYCARBONATE GP BACK HOUSING	1	SHEFFIELD PLASTICS
5	4-1/8" POLYCARBONATE GP BASE SPACER	7	SHEFFIELD PLASTICS
6	SELF ADHERING MEMBRANE	AS REQD.	SBS Self Adhering
7	1/4" X 8" HOT DIPPED GALV. HEX BOLT W/ FLAT & LOCK WASHERS WITH 1/4" X 20 SNAPTOGGLE ANCHORS	6	SNAPTOGGLE
8	5/16" X 8" HOT DIPPED GALVANIZED LAG SCREW	1	PURCHASE

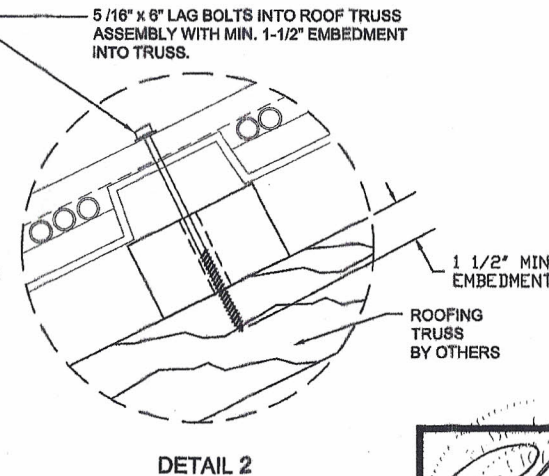
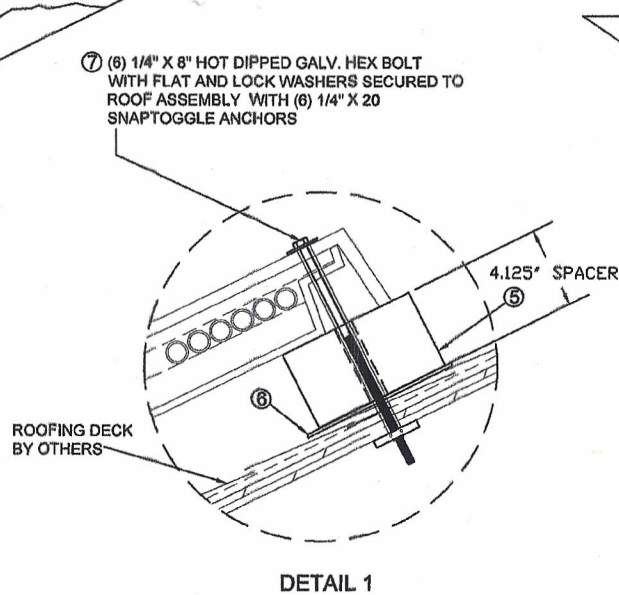
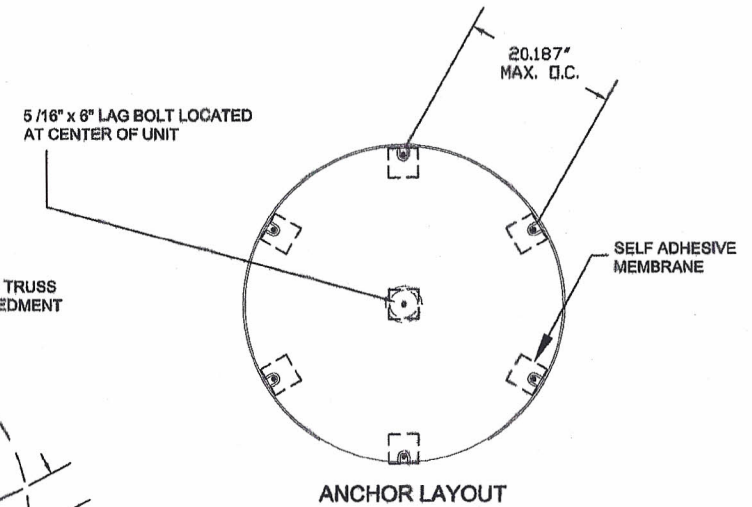
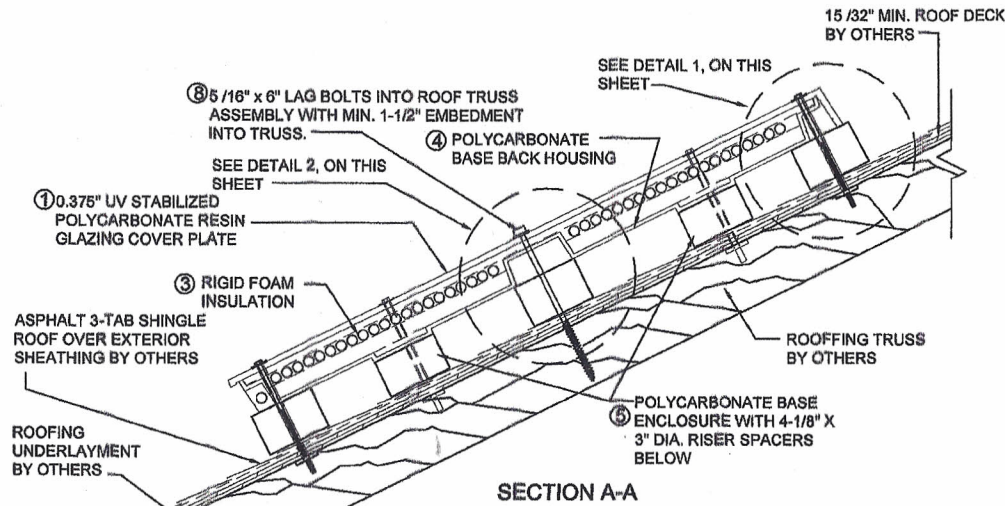

Approved as complying with the Florida Building Code
 Date 06/14/2012
 NOA# 11-1012.01
 Miami Trade Product Control
 By *[Signature]*

[Signature]
 12/07/2011
 PAUL E. WINTER, P.E.
 Florida P. E. No. 22693

SOLAR COIL, LLC 1257 FLUSHING AVENUE CLEARWATER, FL 33764		
TITLE: SC092809BK PASSIVE SOLAR COLLECTOR ANCHOR DETAILS AND B.I.M.		
DRN:	RM	DATE: 05/31/11
SCALE:	N.T.S.	DWG. NO: SC_0001
REV:	A	SHEET: 2 OF 3

REV	PER MIAMI DADE COMMENTS	12/07/11
SYM	REVISION	DATE BY

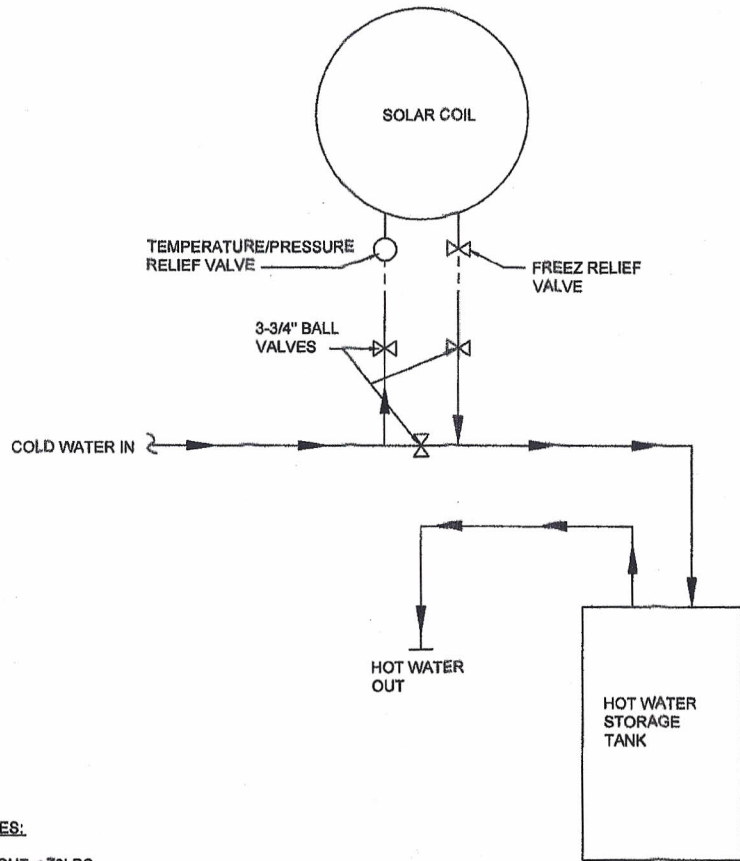

**TANK TYPE WATER HEATER
PIPING DIAGRAM**

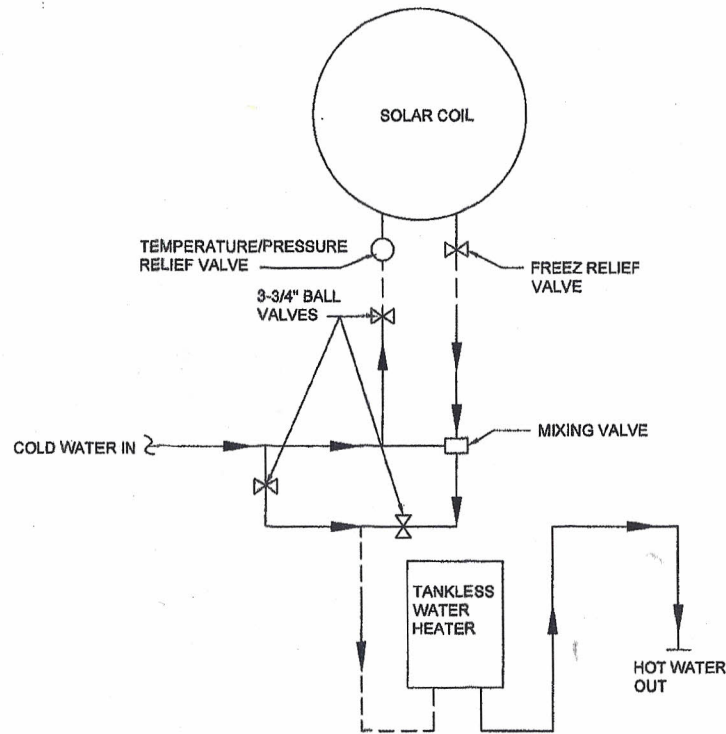

**TANKLESS WATER HEATER
PIPING DIAGRAM**

GENERAL NOTES:

- 1. SAMPLE WEIGHT = 73LBS
WHEN FULL OF WATER
- 2. MAXIMUM WORKING PRESSURE
AT 2 X 80 PSI = 160 PSI.

Approved as complying with the
Florida Building Code
Date *06/14/2012*
NOA# *11-012.01*
Miami Dade Product Control
By *[Signature]*

REV	PER MIAMI DADE COMMENTS	DATE BY
SYM	REVISION	DATE BY
		12/07/11

Paul E. Winter
12/07/11
PAUL E. WINTER, P.E.
Florida P. E. No. 22693

SOLAR COIL, LLC 1257 FLUSHING AVENUE CLEARWATER, FL 33764	
TITLE: SC092809BK PASSIVE SOLAR COLLECTOR PIPING DIAGRAM & WORKING PRESSURES	
DRN: RM	DATE: 05/31/11
SCALE: N.T.S.	DWG. NO: SC_0001
REV: A	SHEET: 3 OF 3