



INSTRUMENTS, INC.

468 Liberty Drive
Wittenberg, WI 54499
U.S.A.

Tel: 715- 253-2801 Ver.11-18-2008
Fax: 715- 253-2811
Web: www.solar.imcinstruments.com

SERVICE AND INSTALLATION INSTRUCTIONS



IMC's LCD MASTER DIGITAL DISPLAY PANEL
for REMOTE indication

EAGLE D1

12VDC-POWERED

SUN CONTROL

DIFFERENTIAL TEMPERATURE CONTROLLER

MAIN FEATURES

- **Microprocessor** accuracy and dependability with ambient operation from -10 to 120°F
- **Large easy-to-read 40 character** (20x2) backlit LCD display showing every parameter measured and controlled by the microprocessor.
- **PC DATA PORT** with built-in transmitter allows optional adapter and up to 500 ft. cable to interface with computers for ease in startup and remote diagnostics. Or, for adding an **Optional large 80 character** (4x20) backlit LCD display. Remote-mount up to 150 ft. distances with a CAT-5 cable.
- **Long-term diagnostics** and data logging is possible using communications software that is included in Windows' OS.
- **Fault LED indicators** for quick servicing and diagnostics
- **Features for fast installation** and wiring
- **Electrostatic** discharge protected
- **One HP or 20 AMP** high reliability relay
- **Polyester coated 16 gage** rugged steel enclosure with 1/2" conduit holes for permanent wiring
- **Two industrial 400°F (204°C) rated 10 K thermistors** with +/- 1°F accuracy are included.
- **Two auxiliary thermistor inputs** for optional sensors that can be located up to 1000' away.
- **Selectable overrides** for **low temperature shut down** or **freeze protection** modes for safe operation.

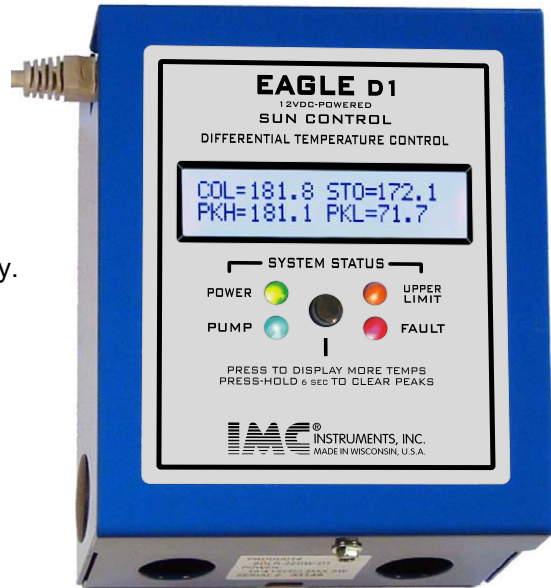

PR# SOLR-2EDW-D1

LCD DISPLAY

The LCD display has 2 lines of 20 characters each. The first line permanently displays the COLLECTOR and the STORAGE temperatures. The second line can be paged by pressing the button located just below the LCD display. The following 4 pages display all system information including OVERRIDE messages.

PG 1



PG 2



PG 3



PG 4



SYSTEM OVERRIDE MESSAGES **FLASH** on the LOWER LCD LINE as follows:

LOWTEMP-PMP>OF

FREZE-PMP->ON

INSTRUMENTATION WITH QUALITY ENGINEERING

DATA-PORT

Requires an IMC Data-Port ADAPTER that will allow interface to a standard computer's serial RS232 port. The ADAPTER can also accept a serial to USB converter to connect directly to portable computers that only have USB ports. If wireless operation is desired for short distances, BLUE TOOTH transceiver can also be connected. The rate at which the data is sent from the EAGLE solar controller is determined by a jumper in the controller as show in the CONTROLLER diagram on page 4. If the jumper is placed on position labeled "2S", one complete line of "total system information" will be sent to the computer every 2 seconds which is necessary when performing diagnostics or a system startup. If the same jumper is placed on position labeled "6M", then data will be sent every 6 minutes. This will allow a more suitable data-send rate for long-term DATA LOGGING, specially when storing the data in a "CAPTURE" file setup in the computer's communications program such as "Terminal" or "Hyper Terminal".

SAMPLE DATA PORT PRINT

RUNTIME	COLL-T	STOR-T	DIFF-T	HILI-T	AUX-1	AUX-2	PUMP	UPLim	FAULT	
0:00	125.9	73.7	08.0	110.0	212.2	205.4	ON	OFF		System collecting solar HEAT
0:06	25.9	73.7	08.0	110.0	212.2	205.4	OFF	OFF	LO-TMP->OFF	System in LO TEMP shut down PUMP->OFF
0:12	25.9	73.7	08.0	110.0	212.8	205.4	ON	OFF	PmpSW!	Pump switch ON
0:18	OPEN.S	73.9	08.0	110.0	212.8	205.4	OFF	OFF	SENS! , PmpSW!	Open sensor, pump switch OFF
0:24	-16.0	74.7	08.0	110.0	25.9	184.6	ON	OFF	FREZE-PMP->ON	System in Freeze protect mode PUMP->ON
0:30	SHRT.S	74.9	08.0	110.0	25.9	154.6	OFF	OFF		Shorted sensor->System OFF
0:36	125.9	173.7	08.0	173.0	112.2	95.4	OFF	ON		Storage reached UPPER LIMIT

An **IMC LCD MASTER DIGITAL DISPLAY PANEL** can also be connected to the DATA PORT. It has an RJ-45 jack and is supplied with a 3 foot long cable that can be substituted with a standard CAT5 cable up to 150 feet long. These ethernet cables are available at most retail stores. The display panel also has a PEAK RESET button located on the side to reset previous STORAGE temperature peaks.

The Information on the **LCD MASTER DISPLAY PANEL** is displayed as follows:

COLLECTOR TEMPERATURE
 STORAGE TEMPERATURE
 DIFFERENTIAL CONTROL SETTING
 HI LIMIT CONTROL SETTING
 PUMP STATUS
 UPPER LIMIT STATUS
 PEAK HI= MAXIMUM TEMPERATURE
 PEAK LO= MINIMUM TEMPERATURE
 AUXILIARY SENSORS 1 AND 2

PAGE 1



COL=174.1	STO=110.4
PKH=180.4	PKL=60.1
DIF=08.0	HIL=175.3
PMP=ON	UPL=ON

This Master LCD has a second page that will display the auxiliary sensor temperatures. To display, press and release the PAGE/RESET button on the side of the display housing. The auxiliary sensors will be displayed within 2 seconds. To RESET the STORED PEAK temperatures of the storage tank, press and hold for 6 seconds the PAGE/RESET button. The current temperatures will appear after the button is released. The Master LCD display is updated every 2 seconds.

PAGE 2

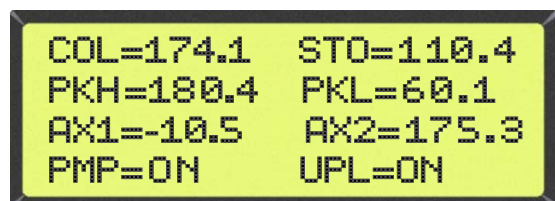

COL=174.1	STO=110.4
PKH=180.4	PKL=60.1
AX1=-10.5	AX2=175.3
PMP=ON	UPL=ON

IMPORTANT NOTICE

These EAGLE Series Temperature Controls are intended to control equipment under normal operating conditions. Where failure or malfunction of EAGLE Series Control could lead to an abnormal operating condition that could cause personal injury or damage to the equipment or other property, other devices (limit or safety controls) or systems (alarm or supervisory) intended to warn of or protect against failure or malfunction of the EAGLE Series Control must be incorporated into and maintained as part of the control system.

CONTROLLER OPERATION

TEMPERATURE DIFFERENCE CONTROL- When the temperature difference between the sensor on the solar collector and the sensor in the storage tank exceeds the dialed temperature difference setting (ON DIF), the PUMP relay will actuate after a 30 second delay. The BLUE LED indicator will also turn ON. When the temperature difference decreases and falls below 4°F (2.2°C), the PUMP relay and the BLUE LED indicator will turn off without delay.

HIGH LIMIT CONTROL- When the temperature in the storage tank exceeds the HI-LIMIT dialed setting, the PUMP relay will be turned OFF without delay regardless of the status of the temperature difference that exists between the STORAGE tank and the solar COLLECTOR. The BLUE LED indicator will also turn OFF. When the storage tank temperature falls 4 degrees below the setting in the HI-LIMIT, the controller will then resume normal operation. The PUMP relay will always have a 30 second delay before switching ON and the BLUE LED will always show its STATUS condition.

LOW TEMPERATURE SHUT-DOWN OVERRIDE- This feature is available to prevent the system from operating at low outdoor temperatures. If this feature is enabled, normal operation will stop when the COLLECTOR temperature falls below 50°F. The PUMP relay will then be turned OFF. Normal control operation will not resume until the COLLECTOR temperature returns to 70°F or above. To enable this feature, a jumper must be placed onto the jumper pins marked "LO" on the circuit board. Only ONE of these two override features can be enabled.

FREEZE PROTECTION OVERRIDE- This feature is available to prevent a non-drain back "water only" system from freezing when the outdoor temperature drops too low. If this feature is enabled normal operation will stop when the COLLECTOR temperature falls below 37°F. The PUMP relay will then be turned ON until the COLLECTOR temperature reaches 52°F. Normal control operation will resume above this temperature. To enable this feature, a jumper must be placed onto the jumper pins marked "FZ" on the circuit board. Only ONE of these two override features can be enabled.

STATUS INDICATION LEADS- There are four status indication LEADS. The GREEN LED indicates that the microprocessor is POWERED and the SOLAR controller is running. The BLUE LED indicates PUMP operation. When ON, the PUMP is operating and solar energy is being stored in the STORAGE tank. The AMBER LED indicates if the UPPER LIMIT temperature in the storage has been exceeded. The RED LED indicates when there is a fault condition. The conditions that can cause the fault LED to turn ON are as follows: OPEN or SHORTED or OUT of RANGE temperature SENSORS, pump RELAY SWITCH NOT set to "AUT" (automatic) position and internal component malfunctions. The RED LED will always be FLASHING when the FAULT indication is ON

SENSORS- Industrial 400°F (204°C) rated 10K IMC thermistors have +/- 1°F accuracy. When installed, they will not exceed ONE degree of additional error for cable distances up to 1000 feet of 18ga., 700 feet of 20ga. or 500 feet of 22ga.

SENSOR SCREW TERMINALS- There are 9 screws on a GREEN block located at the top edge of the board. These terminals accept solid or stranded wire from 18ga. to 22ga. They are NEC class 2 circuit connections.

POWER AND RELAY TERMINALS- This model operates on 12 vdc @ 2 watts. Operation outside 10 vdc to 15 vdc is not guaranteed and operation above 15 vdc will void warranty. The relay is UL & CSA rated for 20 amps resistive load on the normally open (N.O.) contacts and can be used to power PUMPS or FANS directly not exceeding a total of 1 hp. The "normally closed" contacts are rated for 10 amps resistive or a maximum of 1/4 hp. For D.C. operation, the relay is UL & CSA rated for 20 amps at 30 volts on the normally open (N.O.) contacts and 15 amps on the normally closed (N.C.) Contacts.

INSTALLATION

MOUNTING- The Eagle line of SOLAR controllers are designed to be mounted indoors, protected from rain and condensing moisture. Use two #10 screws in the enclosure “keyholes” for mounting.

POWER WIRING- When connecting the relay to switch 120 vac power, the 12 vdc circuit wiring must have insulation rated for at least 300 volts. Terminal connections are designed for 14 to 18 ga stranded or solid wire but when using 14 ga, the stranded type is easier to manage. All wiring must be done in accordance with local codes. Line and power wires should NOT be bundled with or placed in the same conduit with sensor or data cables.

SENSOR INSTALLATION AND WIRING- Sensor installation should be in a manner as to permit proper sensor contact of the areas to be measured. Shield and/or insulate the sensors to prevent them from being affected by the surrounding ambient temperatures. Sensor wiring installed outdoors must be rated for OUTDOOR use. All connections exposed to the weather must be made with waterproof “outdoor” rated connectors.

It is recommended in today’s Radio interference “RICH” environment that all sensor wiring be shielded. Listed below are a few suggested wire part numbers. Wire selected must also meet local codes and be rated for indoor/outdoor use by its manufacturer.

- | | | |
|----|---|---------------------------|
| 1) | “PLTC” Belden # 9322 (22ga) or 9320 (20ga) | Best specifications |
| 2) | “Control” Belden # 8761 (22ga) or 8762 (20ga) | Better specifications |
| 3) | “Audio” Belden # 9451-10 Black (22ga) | Acceptable specifications |

The cable SHIELDS must be brought to the shield grounding terminal that is the rightmost position on the GREEN terminal block. See controller layout diagram. For ease of shield installation, insert one short wire in the shield terminal labeled “SHLD” and connect all the shields together with a “wire-nut” or other reliable means. Ungrounded shields may result in damage to the Solar controller circuits. The shield requires grounding at the controller side ONLY. DO NOT attempt to ground the collector panel with the sensor shield.

For efficient and reliable wire connections, strip 3/8” (slightly shorter than block width) of insulation from an undamaged wire end. Use a strip tool that will not nick the conductors. If wire is solid, make sure that the tip is NOT pinched or deformed so that it will fit into the terminal hole easily. If the wire is stranded, make sure the strands are tightly twisted. Using a 1/8” (3mm) wide blade screwdriver, select the appropriate screw and turn CCW to open the terminal hole fully. Then guide the wire into the terminal hole and hold while tightening (turn CW) the screw to clamp the wire. **WARNING-** If a 5/32” (4mm) wide screwdriver blade is used, the screw retaining edge of the hole will be scraped off allowing the screw to fall out. DO NOT reverse the screw turning directions and place the wire outside the metal CAGE creating an unreliable connection. DO NOT slip off the screw and damage any circuit components. If the wire is stranded, make sure that ALL the strands are properly clamped in the terminal.

COLLECTOR GROUNDING- The Solar collector panel array “must be GROUNDED” directly to an earth ground line. This is necessary to prevent damage from nearby lightening strikes which induce very DAMAGING high voltages in all nearby ungrounded metallic surfaces. Please consult local, state and federal codes for proper grounding.

DATA LOGGING TO A COMPUTER- All the EAGLE Solar controllers can be connected to the serial port of a PC or Laptop computers. An IMC DATA PORT/RS232 adapter is required. The maximum recommended adapter cable length is 500 feet. All Windows operating systems have a communications programs such as “Terminal” or “Hyper Terminal” which are used to receive and/or CAPTURE data from the PC’s serial port. This feature is “EXTREMELY” valuable in starting up newly installed SOLAR systems. Long-term data logging is now possible which can be very useful in service and diagnostics of intermittent malfunctions. Complete “system status” including temperature is presented in a line by line format including timer information. In applications where the computer’s interface is going to be permanent it is recommended that the EAGLE WEB model be used in order to protect the connecting computer from electrical surges.

Please visit our website for news or more detailed instruction at “www.solar.imcinstruments.com”.

SPECIFICATIONS

Input Power: 2 Watts @ 12 VDC*
Relay Contact Ratings: #832 UL #E88991, CSA #1429333
Common (CM)- 30VDC MAX. or 250VAC MAX.**
Normally Open (NO)- 20A resistive*** @ 120VAC & 250VAC**
 1 HP @ 120VAC; 2 HP @ 250VAC**
 20A @ 30VDC**; TV-5
Normally Closed (NC)- 20A resistive*** @ 120VAC & 250VAC**
 1/4 HP @ 120VAC; 1/2 HP @ 250VAC**
 15A @ 30VDC**

Relay Action: 30sec delay ON; no delay OFF
Differential: Adjustable 8 to 24°F; fixed 4°F reset
High Limit: Adjustable from 110 to 200°F
Accuracy: +/- 1 °F
Sensors: 10K @ 77°F (25°C) Rated to 400°F
Environmental: -10 to 120°F @ 0 to 95 %RH
Dimensions: 5.00"W x 6.12"H x 2.50"D
Weight: Appx. 2.0 lbs without power cord

* 10V min. to 15VDC max. Warranty is VOID if voltage exceeds 15 DC
 ** 120VAC or 250VAC supply required at CM
 *** 30 Amp configured model is available

Product #
SOLR-2EDW-D1
 With Conduit Holes
 for Permanent
 Wiring

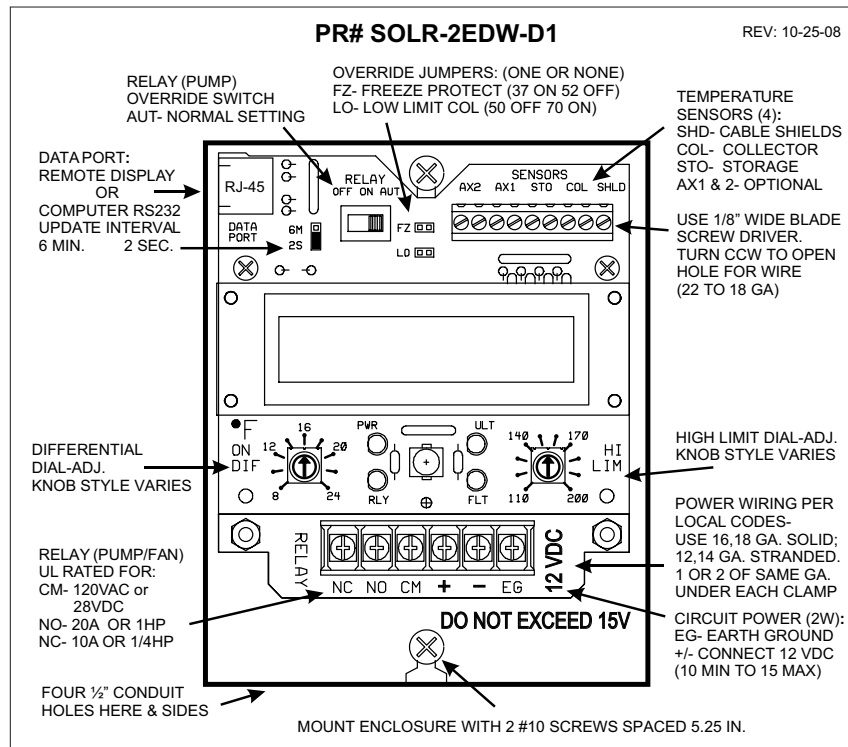

CONTROLLER:	RATING	PRODUCT #
With conduit holes for permanent wiring -	20 Amp	SOLR-2EDW-D1

EAGLE Model SOLR-2EDW-D1 12 VDC BATTERY POWERED SOLAR HOT WATER SYSTEM

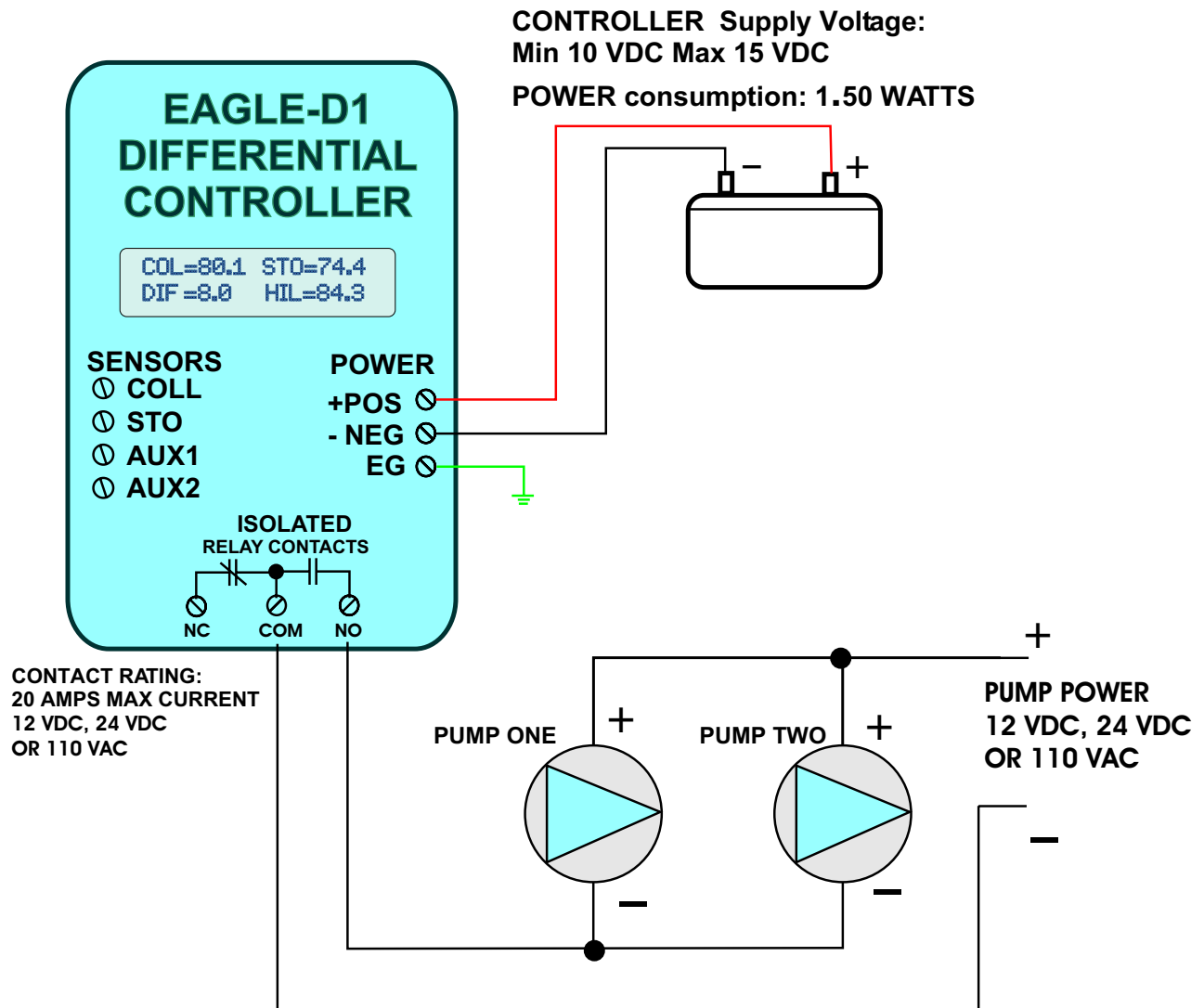

DATE 8-13-2008

ACCESSORIES

THERMISTOR TEMPERATURE SENSORS-
RATED TO 400°F:



Bolt-on style: SOLR-TS02



Screw-in style: SOLR-TS03
1/2-NPT threaded plug



Immersion style:
4"long with 1/4NPT fitting- SOLR-TS04
1/2NPT fitting- SOLR-TS24
8"long with 1/4NPT fitting- SOLR-TS05
1/2NPT fitting- SOLR-TS25

PC Data-Port Adapter RS-232*: SOLR-DA10

Connects directly to the EAGLE controller DATA-PORT and permits serial PC communication at 2400 BAUD rate. * non-isolated

Adapter has a 7 foot cable terminated with an RJ-45 plug.

EAGLE "web" controller with a 2500 volt isolated PORT is recommended for long-term or permanent installations.

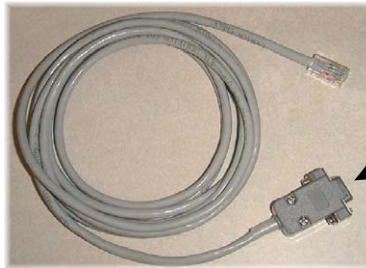

Includes electronic circuits inside the DB-9 connector housing.

ACCESSORIES continued

LCD MASTER DIGITAL DISPLAY PANEL- SOLR-RD80

Displays temperature and status indication with 80 characters (4x20) 1/4" high.
Supplied with a 3' foot CAT-5 cable that connects directly to the EAGLE controller Data-Port*.
Housing dimensions are 4.33" (110mm) wide x 2.34" (82mm) high x 1.73" (44mm) deep.



*** IMPORTANT NOTICE**

Do NOT attempt to connect any ETHERNET device or any other non-IMC devices to the RJ-45 DATA-PORT of any IMC CONTROLLER or accessory. This will result in damage to the connected equipment. Connect ONLY devices specifically designed by IMC Instruments to be connected to these ports.

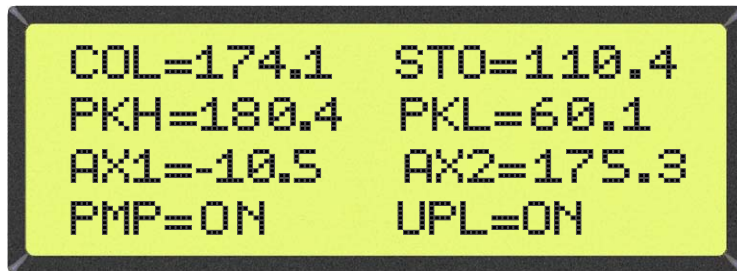

ACTUAL SIZE DISPLAY
when printed booklet size