



CERTIFIED SOLAR SYSTEM

SUPPLIER:
Alternate Energy Technologies
 1345 Energy Cove Court
 Green Cove Springs, FL 32043 USA
 www.aetsolar.com

BRAND: EAGLESUN DX
 MODEL: DX-80-48
 SYSTEM TYPE: Pumped, Indirect
 CERTIFICATION #: 2006007I
 Original Certification: May 06, 2010
 Expiration Date: October 29, 2014

The solar system listed below has been evaluated by the Solar Rating & Certification Corporation™ (SRCC™) in accordance with SRCC OG-300, Operating Guidelines for Certifying Solar Water Heating Systems, and has been certified by the SRCC. This award of certification is subject to all terms and conditions of the Program Agreement and the documents incorporated therein by reference.

Description: Glazed Flat Plate, Differential, External Shell and Tube Heat Exchanger, -51 °C -60 °F, Non-GRAS, UL listed electric tank, Drainback

Single-day Rating		SINGLE DAY RATING CONDITIONS	SI Units	Inch-Pound Units
Solar Energy Factor (SEF _D)	Solar Fraction (SF _D)	System Set Temperature	57.2 °C	135 °F
1.90	0.52	Environmental Temperature	19.7 °C	67.5 °F
Single-day Rating Conditions: SEF _D = Solar Energy Factor (info link) SF _D = Solar Fraction (info link)		Ambient Temperature Profile Average	14.4 °C	58 °F
		Water Mains Temperature	14.4 °C	58 °F
		Delivered Load	43.3 MJ/day	41,045 Btu/day
		Solar Irradiance	4,733 Wh/m ² -day	1,500 Btu/ft ² -day

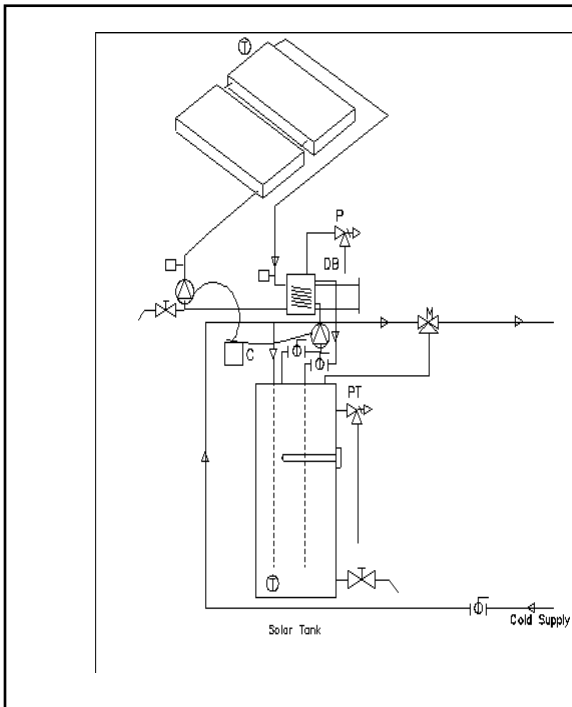

Storage Tank(s)	
Solar Tank Vol (l)	Solar Tank Vol (gal)
303	80
Approximate Collector Area: 4.4 m ² , 47.6 ft ²	

The solar water system listed here has been certified by the SRCC as meeting the minimum standards for testing, installation, operation, maintenance, performance, reliability and safety as specified in SRCC Document OG-300. Thermal performance ratings are based on the successful durability and performance testing of a sample collector, where said tests have been conducted by an independent laboratory approved and listed by the SRCC. The system has been modeled using the computer simulation program TRNSYS to calculate the ratings.

Before the Supplier can make any change in design, materials, specifications, parts, or construction, the change(s) must be reported to the SRCC for evaluation of continued certification.

REMARKS:

Jen Higgins

Technical Director





CERTIFIED SOLAR SYSTEM

SUPPLIER:
Alternate Energy Technologies
 1345 Energy Cove Court
 Green Cove Springs, FL 32043 USA
 www.aetsolar.com

BRAND: EAGLESUN DX
 MODEL: DX-80-48
 SYSTEM TYPE: Pumped, Indirect
 CERTIFICATION #: 2006007I
 Original Certification: May 06, 2010
 Expiration Date: October 29, 2014

The solar system listed below has been evaluated by the Solar Rating & Certification Corporation™ (SRCC™) in accordance with SRCC OG-300, Operating Guidelines for Certifying Solar Water Heating Systems, and has been certified by the SRCC. This award of certification is subject to all terms and conditions of the Program Agreement and the documents incorporated therein by reference.

Only the following options for the collector array are approved:

Option	Collector Panel Manufacturer	Collector Panel Request Number	Collector Panel Model Number	Collector Panel Name	Quantity	Total Panel area(m ²)	Total Panel area(ft ²)
1	Alternate Energy Technologies	2002001B	AE-24	Alternate Energy	2	4.42	47.61

Option	Collector Panel Manufacturer	Collector Panel Request Number	Collector Panel Model Number	Collector Panel Name	Quantity	Total Panel area(m ²)	Total Panel area(ft ²)
2	Alternate Energy Technologies	2002002B	MSC-24	Morning Star	2	4.55	49

