

# GI-10W Solar LED Lighting System



## Built to Perform

Carmanah's GI-10W Solar LED Lighting System is a 10-watt solar power supply with accompanying energy efficient luminaires for security and general illumination purposes. The closely designed beam pattern makes this a neighbourhood friendly system with minimal spill light.

The GI-10W Solar LED Lighting System is designed to operate flawlessly through both hot and cold conditions, delivering reliable performance while withstanding rain, snow, ice and wind.

## Innovative Solar Design

The GI-10W Solar LED Lighting System is built using Carmanah's core energy management system (EMS), a technology developed and refined for over a decade and proven in more than 250,000 installations in 110 countries.

Carmanah's patented, Automatic Light Control (ALC) ensures reliable, year long operation. In addition, the GI-10W Solar LED Lighting System's operating profiles can be configured to optimize light output for the heaviest times of pedestrian activity.

**3-Year Warranty!**

## A Complete Solution

The GI-10W Solar Lighting System is designed to encapsulate the energy management system, solar panels and batteries into one small self-contained unit, true differentiators that set Carmanah ahead of component based products.

With the GI-10W Solar Lighting System, installation is possible anywhere at minimal cost as the system comes with everything you need to provide outdoor lighting without the need for external power or trenching.

## Quality is Assured

Carmanah manufactures in accordance with ISO 9001:2000 Quality Standards. The GI-10W is backed by a 3-year warranty.

## Applications

The GI-10W Solar Lighting System is ideal for installations where traditional power is unavailable or challenging to connect to, and can be used for security and guidance lighting for:

- Walkways and bikeways
- Rest areas
- Parking Lots
- Sign Illumination\*

\*With specialized sign luminaire.



LED-4

LED-12F

Specialized sign luminaires as well as an optional elliptical beam luminaire, which can be optimized for pathway lighting, are also available.

CHANGE THE WORLD WITH US™

Toll-Free: 1-877-722-8877

Worldwide: + 250-380-0052

www.carmanah.com



# GI-10W Solar LED Lighting System

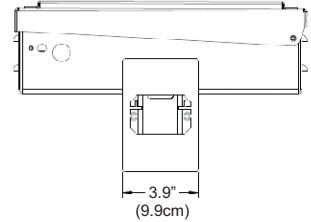
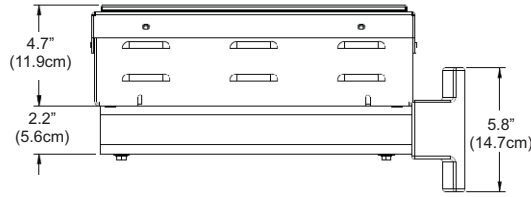
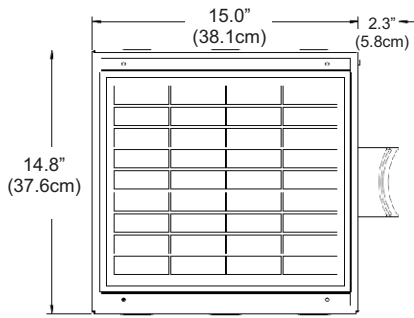

## SPECIFICATIONS

### Solar Module

Construction	High efficiency, polycrystalline
Maximum power	10 watts
Nominal voltage	12 volts
Maximum voltage	17 volts
Maximum current	0.57 amps

### Battery

Construction	Maintenance-free, sealed lead acid
Nominal voltage	12 volts
Maximum capacity	16 Ah

### ENVIRONMENTAL

Operating temperature range	5° F to 122° F (-15° C to +50° C)
-----------------------------	-----------------------------------

### ENERGY MANAGEMENT SYSTEM

Minimum Autonomy (Based on dusk to dawn operation)	132 hours (5.5 days)*
Minimum equivalent peak sun hours to maintain minimum autonomy	2.7 hours

### PERIPHERALS

Luminaires	One to two luminaire capability
------------	---------------------------------

### CONSTRUCTION

Housing	High-grade, corrosion resistant aluminum
Finish	White powder coated
Hardware	Security hardware used on exposed surfaces
Weight	30lbs (13.6kg)

### QUALITY STANDARDS

Quality certification	ISO 9001:2000 Certified Manufacturer
-----------------------	--------------------------------------

### WARRANTY

3 year pro-rated warranty on entire system including batteries

\* Actual performance will vary depending upon insolation environment, operating profile, equivalent days no sun and day.  
All specifications are subject to change without notice.

## REPRESENTED BY

**Jeff Peters**  
Business Development Manager,  
Transit Division  
www.carmanah.com  
Email: [jpeters@carmanah.com](mailto:jpeters@carmanah.com)

**Marion Randell**  
Business Development Manager,  
Transit Division  
www.carmanah.com  
Email: [mrandell@carmanah.com](mailto:mrandell@carmanah.com)

Toll-Free: 1-877-722-8877 (North America)  
Worldwide: +1 (250) 380-0052  
Fax: +1 (250) 389-0040

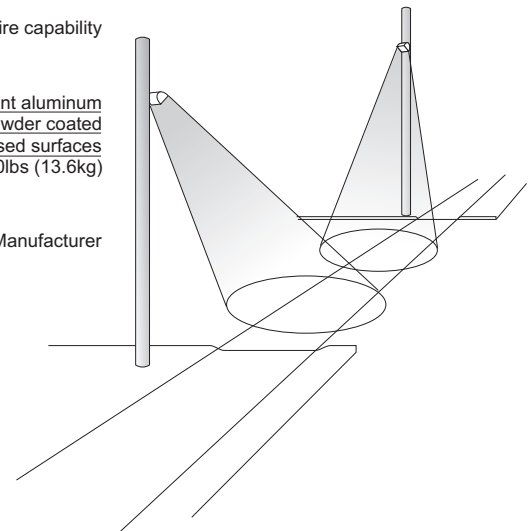

Carmanah Technologies Corp.  
Toll-Free: 1-877-722-8877 (North America)  
Worldwide: +1 (250) 380-0052  
Fax: +1 (250) 389-0040  
Web Site: [www.carmanah.com](http://www.carmanah.com)

Carmanah is a Canadian public corporation  
TSX: CMH

© 2007 Carmanah Technologies Corp.  
"Carmanah" and Carmanah logo are trademarks  
of Carmanah Technologies Corp.  
Document: SPC\_GENILL\_GI-10\_va

