



# SunRise Solar-Powered Attic Fan

## Round Unit with Flat Base

### Installation Guide



Model Shown: # RFB 1250

#### Available Models:

RFB 1250

RFB 1250 FT

- For normal sloped, shingled roofs.
- Also works well with flat concrete tile or slate roofs.

**Made in the USA**

5 yr warranty on motor  
10 yr panel warranty



## INSTALLATION STEPS

**NOTE:** For best operation, install solar fan where it will receive direct sunlight. South or West facing roof slopes will work best.

- 1.) Cut a 14 1/2" diameter hole between rafters approximately 28"-30" down from roof peak to center of hole.
- 2.) Trim away top rows of shingles an additional 2" to allow base flashing to slip under top rows of shingles and over bottom rows.
- 3.) Slip the flat base under the top rows of shingles and center unit over opening with the SRS Logo on the bottom.
- 4.) Gently lift the unit and apply sealant under lower edge and sides of base flashing.
- 5.) Pre-drill (4) mounting holes along the bottom edge of the base flashing, and (1) hole on each side approximately 2" up from the bottom edge.
- 6.) Use exterior-grade screws to secure unit to roof deck. Apply sealant to screw heads.

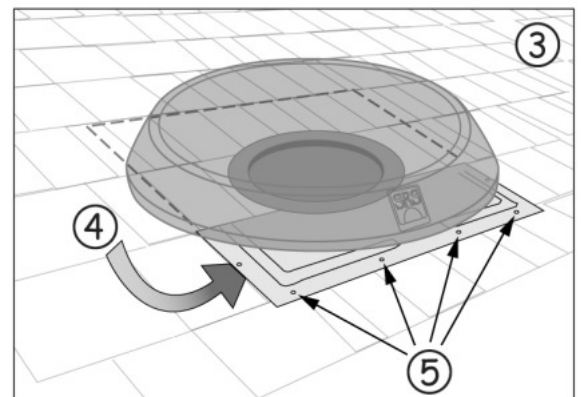
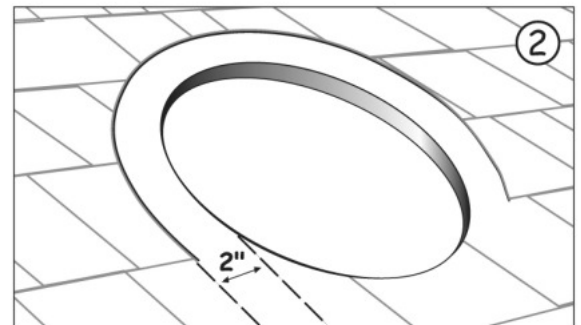
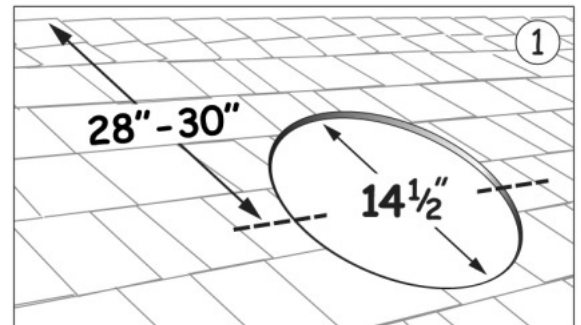

DO NOT OVER-TIGHTEN SCREWS

**Installation Questions?**  
Call 1-219-558-2211



**\* THIS PAGE APPLIES ONLY TO MODELS WITH A FIXED THERMOSTAT**

## Fixed Thermostat Information

This fan has been factory equipped with a thermal on/off switch. This switch is designed to turn the fan:

**ON: 80° F**  
**OFF: 65° F**  
(+/-7°)



Example: Attic temperature rises to 80° and fan turns on. Once it cools to 65° the fan will shut off. If evening comes and temp does not fall below 65° to reset the switch, then the unit will start the next morning at sunrise and continue to cool the attic. However, if the attic temp falls below 65° at night, then the switch will shut off and will not turn the unit on again until attic temp reaches 80°.

**INSTALLER:** THIS FAN WILL NOT RUN UNLESS THE AMBIENT (AIR) TEMPERATURE IS AT OR NEAR 80°. YOU MAY TEST OPERATION OF THE THERMOSTAT BY BLOWING WARM AIR DIRECTLY ON THE THERMOSTAT TO HEAT IT TO 80°, MAKING SURE SOLAR PANEL IS EXPOSED TO SUNLIGHT AT THE SAME TIME.

**SunRise Solar Inc.**

P.O. Box 53

St. John, IN 46373

219-558-2211

219-306-4571 fax

[www.SunRiseSolar.net](http://www.SunRiseSolar.net)

***Taking GREEN...Mainstream!***