



Model CA-28

Four-Chamber Tankless Electric Water Heater

Description: The CA-28 is our commercial model for providing a continuous supply of hot water for as long as you need it. Ideal for the whole house and also for commercial applications such as, specialty restaurants, convenience stores, salons and pet-grooming shops. This on-demand tankless water heater is a powerful replacement for traditional tank-type heaters and is the enabling technology for use as back-up to active renewable energy systems such as solar and geothermal water heating systems. The temperature activated control works effectively in recirculating systems and in combination with tank-type heaters. A minimum 150 AMP whole-house electrical service is recommended.

Features:

- UL 499 Listed for Water Heating Applications
- No minimum flow required for activation
- Built-in DSM Utility Integration option
- Compatible with Home Energy Management
- Very small & compact with no moving parts
- Lightweight modular construction
- Standard 3/4 inch plumbing connections with no flow restrictions
- Compatible with all plumbing designs including recirculating, tubing and manifold systems
- Microprocessor digital control
- Power sharing power control technology
- Heats continuously and only when needed
- Self-diagnostics with redundant safety devices
- High performance DuPont polymer nylon chamber material
- Built-in leak detection and alarm
- Rust & corrosion resistant

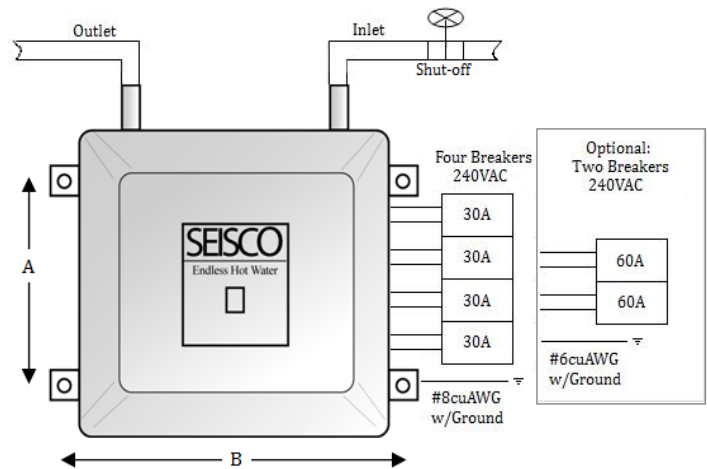
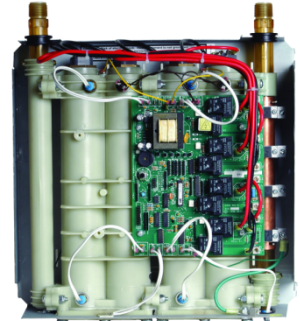

Specifications:

Heat Output (max.): **95,560 BTU**
 Power Rating (max.): **28KW**
 Voltage Rating (Nominal): **240 VAC**
 Current Rating (max.): **116 AMPS**
 Panel Load Factor (40%): **47 AMPS**
 Energy Factor: **0.99+**
 Heating Elements: **7000 watts x 4**
 Circuits Required: **4 ea. 2-wire w/ ground (#8cuAWG)**
 Breakers Required: **Four (4), double-pole**
 Breaker Size: **30 AMPS each x 4 (Optional 60 x2)¹**
 Temp. Output (dial): **90F to 130F (32C - 52C)²**

¹ Install included jumpers on control board for this option and use 2 ea 2-wire circuits w/ground #6cuAWG

² Temperature factory set to 120F (49C)

Flow Ratings:

Rise (°F)
@ Flow (GPM)
 95°F @ 2.0 GPM
 76°F @ 2.5 GPM
 64°F @ 3.0 GPM
 48°F @ 4.0 GPM

Rise (°C)
@ Flow (LPM)
 50°C @ 8 LPM
 40°C @ 10 LPM
 33°C @ 12 LPM
 25°C @ 16 LPM

Mounting Holes:

A: 14 3/4" (362mm)
 B: 16 1/8" (410mm)

Dimensions:

Weight: 23 lbs. (10.4 kg)
 Height: 15 3/4" (400mm)
 Width: 15 3/4" (400mm)
 Depth: 6 1/4" (159mm)
 Fittings: 3/4" (200mm)

Approvals:

UL NSF HUD NEC
 (Not approved for Canada)