



FOR COMMERCIAL WATER HEATING APPLICATIONS

Model CA-16

Two-Chamber Tankless Electric Water Heater

Description: The CA-16 is excellent for specialized applications such as single showers or bathrooms. Also ideal for supplementing existing tank-type heaters that are unable to satisfy user requirements in beach houses, hair salons, horse stables, hunting and fishing cabins. Great for small apartments or condominiums where the incoming water temperature rarely drops below 70° F. This on-demand tankless water heater is the enabling technology for use as a booster to a traditional tank water heater or active renewable energy systems such as solar and geothermal water heating systems. The temperature activated control works effectively in re-circulating systems and in combination with tank-type heaters.



Features:

- UL 499 Listed for Water Heating Applications
- No minimum flow required for activation
- Built-in DSM Utility Integration option
- Compatible with Home Energy Management
- Very small & compact with no moving parts
- Lightweight modular construction
- Standard 3/4 inch plumbing connections with no flow restrictions
- Compatible with all plumbing designs including recirculating, tubing and manifold systems
- Microprocessor digital control
- Power sharing power control technology
- Heats continuously and only when needed
- Self-diagnostics with redundant safety devices
- High performance DuPont polymer nylon chamber material
- Built-in leak detection and alarm
- Rust & corrosion resistant

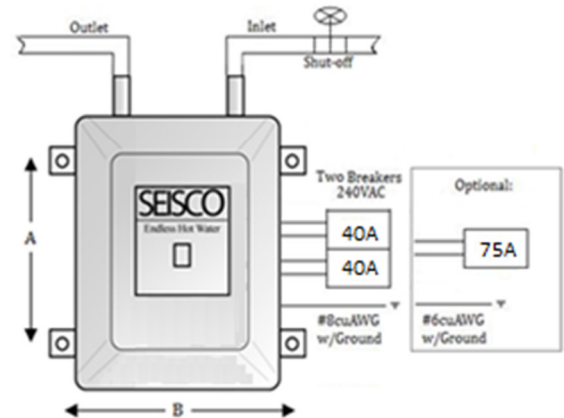

Specifications:

Heat Output (max.): **54,606 BTU**
 Power Rating (max.): **16KW**
 Voltage Rating (Nominal): **240 VAC**
 Current Rating (max.): **67 AMPS**
 Panel Load Factor (40%): **27 AMPS**
 Energy Factor: **0.99+**
 Heating Elements: **8000 watts x 2**
 Circuits Required: **2 ea. 2-wire w/ ground (#8cuAWG)**
 Breakers Required: **Two (2), double-pole**
 Breaker Size: **40 AMPS each x 2 (Optional 75 x1)¹**
 Temp. Output (dial): **90F to 130F (32C - 52C)²**

¹ Install included jumpers on control board for this option and use 1 ea 2-wire circuits w/ground #6cuAWG
² Temperature factory set to 120F (49C)

Flow Ratings:

Rise (°F)
@ Flow (GPM)
 52°F @ 2.0 GPM
 42°F @ 2.5 GPM
 34°F @ 3.0 GPM
 25°F @ 4.0 GPM

Rise (°C)
@ Flow (LPM)
 27°C @ 8 LPM
 22°C @ 10 LPM
 18°C @ 12 LPM
 13°C @ 16 LPM

Mounting Holes:

A: 14 1/4" (362mm)
 B: 10 7/8" (276mm)

Dimensions:

Weight: 15 lbs. (7.0 kg)
 Height: 15 3/4" (400mm)
 Width: 10 1/4" (260mm)
 Depth: 6 1/4" (159mm)
 Fittings: 3/4" (200mm)

Approvals:

UL CSA NSF HUD NEC