



EB-45 Compact Pressure Regulator

The compact EB-45 Series is a half-cartridge based pressure reducing and regulating valve with a lead free bronze body. The valve resembles the traditional regulators with a spring chamber and an adjusting screw but offers the performance of a cartridge based valve. The EB45 is assembled using modular construction methods and features end connections threaded for both FIP and union. These valves are supplied by the factory with a standard delivery setting of 45 psi. The outlet pressure can be adjusted from 10-70 psi without changing the spring.

The compact EB-45 is intended for use where supply line pressure does not exceed 400 psi. This regulator is suited for either cold or hot (to 180°F) water service. All models are lead free.*

- Compact pressure reducing and regulating valves:
Designed for small and economic considerations.
- Listed by IAPMO and to ASSE standard 1003:
Inspector Friendly, peace of mind.
- By-pass mechanism integral with the cartridge:
No add-on or small parts, longer life and more reliable performance.
- Quick and Easy service:
Back off pressure and remove spring chamber, pressure spring and button and replace cartridge and you have a new valve.
- Every valve is tested through a range of tests prior to shipping:
Specify and install with confidence.

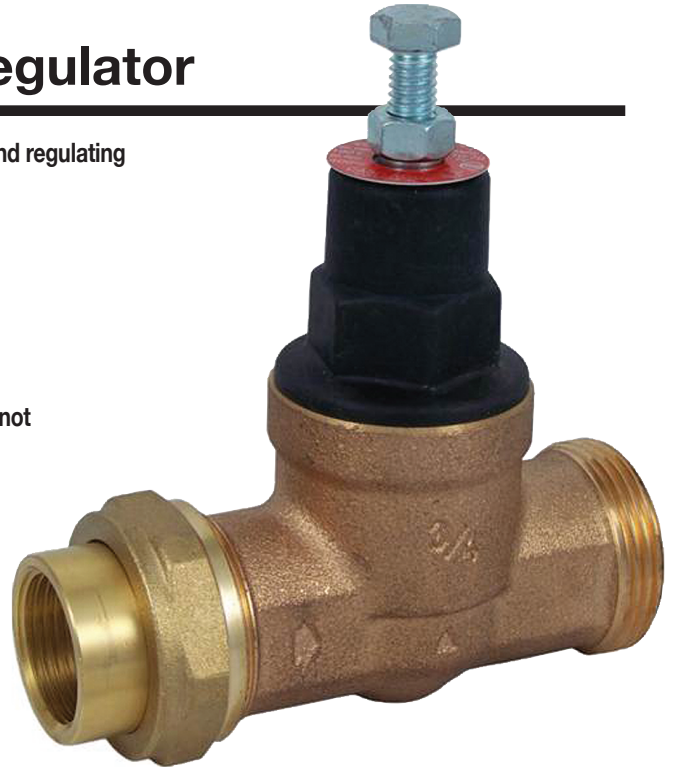

TYPICAL INSTALLATION

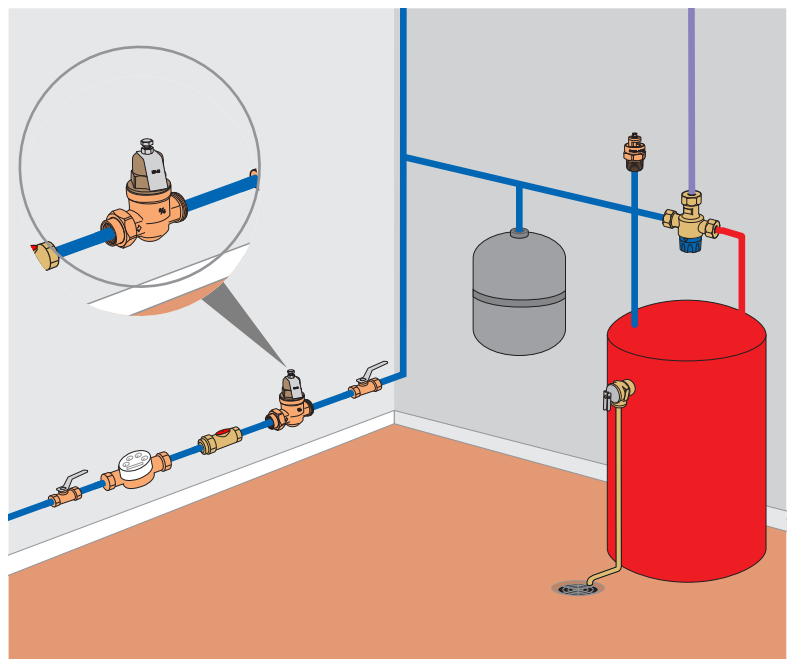



EB-45 Compact Pressure Regulator

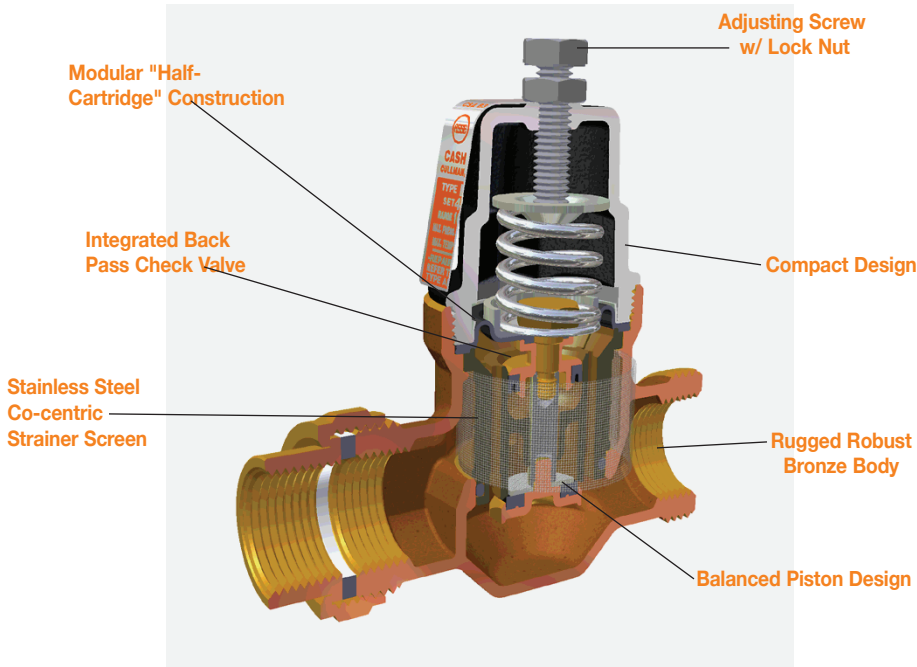

MODELS/SIZES

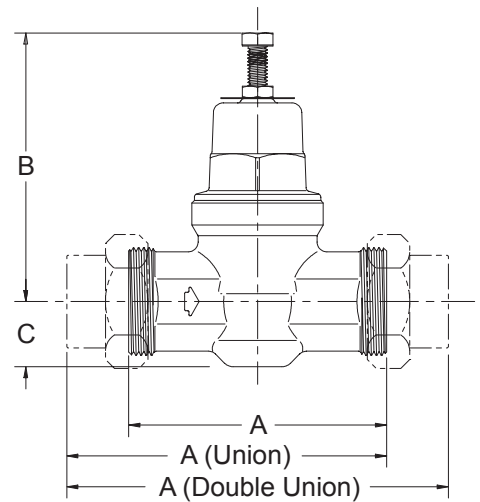

CONNECTIONS

All EB45 models include both FIP and union connection threading on both ends.

Threaded (NPT) Inlet & Outlet.	1/2", 3/4"
Threaded (NPT) Union, Threaded (NPT).	1/2", 3/4"
Sweat Copper Union, Threaded (NPT).	1/2", 3/4"
Threaded (NPT) Union Inlet & Outlet.	1/2", 3/4"
Sweat Copper Union Inlet & Outlet.	1/2", 3/4"
SharkBite® Push-Fit Connection Union Inlet & Outlet	1/2", 3/4"
CPVC Union Inlet & Outlet.	3/4"
PEX Barb Union Inlet & Outlet	3/4"

Valve Size	A	B	C
1/2"	3.23	4.37	0.75
3/4"	3.39		
1/2" Union	3.99		
3/4" Union	4.15	0.87	
1/2" Double Union	4.76		
3/4" Double Union	4.92		

CERTIFICATIONS

CASH Acme Type EB-45 Pressure Regulators are certified to ASSE 1003 and CSA B356 and listed by ASSE and IAPMO (cUPC).

* For all models, surfaces that are in contact with consumable water contain less than 0.25% lead by weight.