

FLORIDA SOLAR ENERGY CENTER

1679 CLEARLAKE ROAD, COCOA, FLORIDA 32922-5703 (321) 638-1000

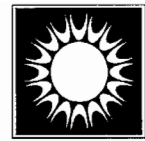

Approved Solar Energy System

FSEC # S4054

Approval Date: MAR 1984

Revision Date: JAN 2004

DISTRIBUTOR	SYSTEM
Thermal Conversion Technology 101 Copeland Street Jacksonville, Florida 32204	ProgressivTube PT-40-CN

This system was evaluated by the Florida Solar Energy Center (FSEC) in accordance with the Florida Standards Program For Solar Domestic Water and Pool Heating Systems (FSEC-GP-7-80) and was found to meet the minimum standards established by FSEC.

The calculated Florida Energy Factors for this system are:

	North	South/Central
	4.1	4.9

Description

Collector Manufacturer	Model Number	Units	Total Rating (Btu)
1. Thermal Conversion Tech.	PT-40-CN	1	28,400*

* Q_{NET} based on FSEC Solar System Test

Tank Manufacturer	Model Number	Capacity (gal)	Type: Direct
1. Integral Storage		41	

Pump Manufacturer	Model Number	Power Draw (Watts)	Rated Power
1. None			

Controller Manufacturer	Model Number	Type:
1. None		

Freeze Protection

1. Thermal mass
2. Manual draining

Other Major Components

1. None

If further information is required you may contact the Florida Solar Energy Center at the above address.

SYSTEM PLUMBING DIAGRAMS

PRE-HEATER SOLAR SYSTEMS

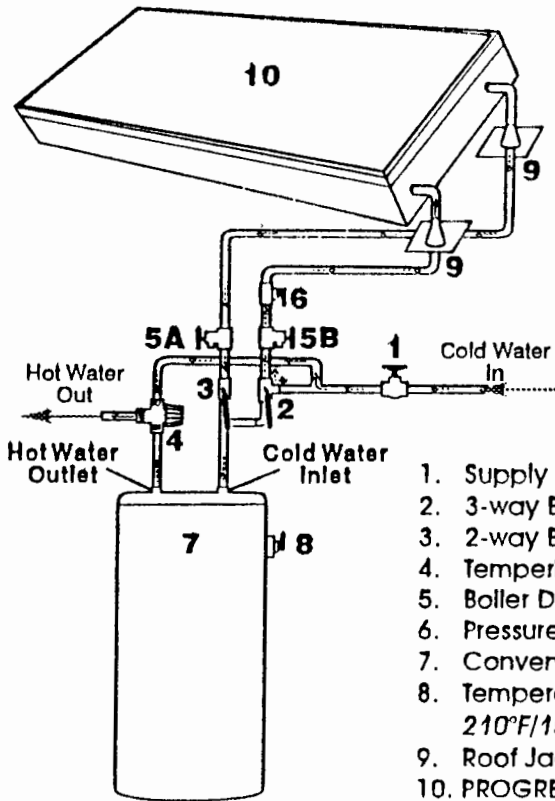

2-WAY SYSTEM

FOR ELECTRIC WATER HEATERS

1. Supply shut off valve
2. 3-way Ball Valve: *Bronze*
3. 2-way Ball Valve: *Bronze*
4. Tempering Valve
5. Boiler Drains: *Bronze*
6. Pressure Relief Valve: *150 psi*
7. Conventional Water Heater
8. Temperature/Pressure Relief Valve:
210°F/150 psi
9. Roof Jacks
10. PROGRESSITUBE®

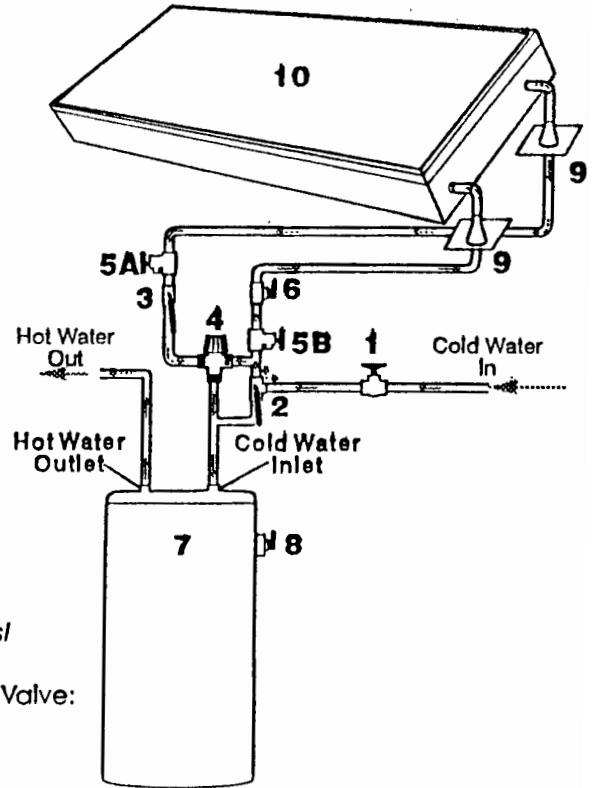

2-WAY SYSTEM

FOR GAS WATER HEATERS