

■ SOLAR COLLECTOR CORRUGATED METAL ROOF MOUNTING INSTRUCTIONS ■

CAUTION

ALL PERSONS WORKING ON ROOFS SHOULD HAVE SUCCESSFULLY COMPLETED A FALL SAFETY COURSE AND SHOULD BE PROPERLY EQUIPPED WITH THE APPROPRIATE SAFETY EQUIPMENT

⚠ WARNING

AFTER COMPLETION OF THE COLLECTOR MOUNTING AND PRIOR TO SYSTEM CHARGING THE COLLECTORS MUST BE COVERED BY A BLANKET OR OTHER MEANS TO AVOID SOLAR RADIATION FROM HEATING THE COLLECTORS. THE SURFACES OF THE COLLECTOR CAN BECOME EXTREMELY HOT AND COULD POSE A BURN HAZARD.

structural members of the roof with the stainless steel hardware provided. The solar collector must be attached to the mounting hardware as detailed in Figure 6.

Preserving the integrity of the roof membrane is the most important roofing consideration. Ensure that all roof penetrations required to plumb and mount the solar collector are properly flashed and sealed in accordance with standard roofing practices.

If the region is subject to hurricane conditions, additional steps may be required to secure the collector and mounting hardware to the structural members. In certain areas of the country, local building codes may require collector wind load testing or prescribe specific mounting procedures. Consult your local building department.

Install the collectors as described in the Corrugated Metal Roof Mounting instructions.

The most important structural consideration is to securely anchor the solar collector and the mounting hardware to the

BASIC TOOLS AND MATERIALS

Drill & Drill Bits
 Extension Cord
 Tape Measure
 Chalk Line
 Torque wrench (Inch Pounds)
 Level
 Pliers
 8" & 10" Adjustable Wrenches

7/16" & 17mm Wrenches
 Ratchet & 7/16" & 17mm Sockets
 6' x 8' or 6' x 10' Tarp (1 per collector)
 Roof Sealant

Installation Hardware (Supplied) Includes:

- Hardware
- Mounting Brackets

CORRUGATED METAL ROOF MOUNTING

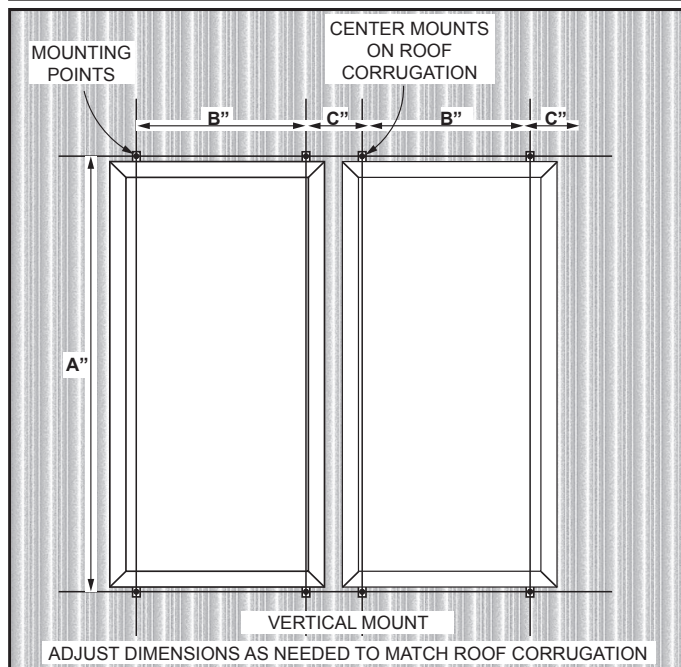

Figure 1.

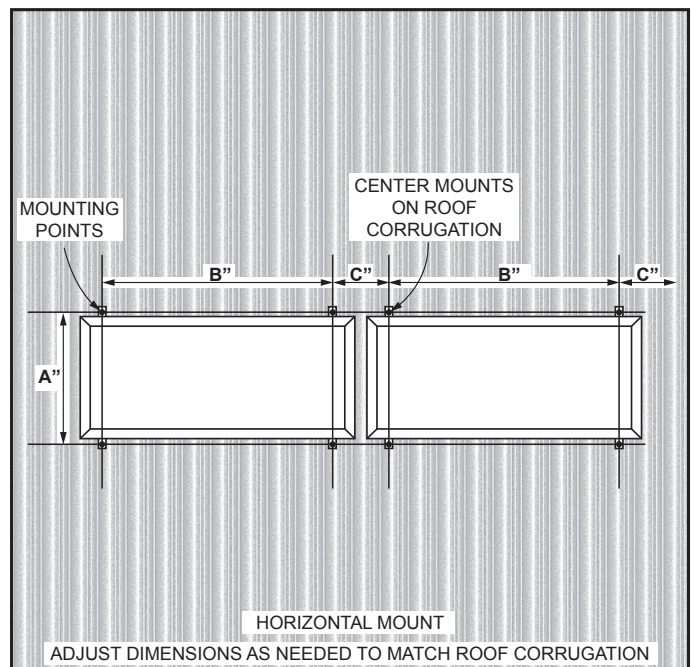

Figure 2.

NOTICE

* IF MOUNTING WITH AN OPTIONAL TILT MOUNT KIT, FOR OPTIMAL COLLECTOR ANGLE REFER TO ITS INSTRUCTION SHEET FOR THE APPLICABLE "A" DIMENSION.

** DIMENSION DEPENDANT ON ROOF CORRUGATION SPACING. ADJUST AS NEEDED.

COLLECTOR	A	B	C
Vert. 3.5' X 7'	86*	32**	14**
Vert. 4' X 8'	97*	35**	16**
Vert. 4' X 10'	121*	35**	16**
Horiz. 3.5' X 7'	42.25*	62**	28**
Horiz. 4' X 8'	47*	72**	28**
Horiz. 4' X 10'	47*	94**	30**

Table 1.

1. Determine the location of the supporting structure of the roof. When possible, secure the corrugated metal roof mounting bracket using all of the hole locations. When not possible, always use the two up-slope hole locations.

IMPORTANT: The corrugated metal roof mounting bracket must be mounted directly over and into the supporting structure of the roof (wood decking, wood or steel trusses). Never mount into the metal roofing material alone.

2. Layout the roof per Figure 1 for vertical mounting, Figure 2 for horizontal mounting, and Table 1. Note that the M10-1.50 bolt hole in the corrugated metal roof mounting bracket should be located at the center of the mounting points shown in Figures 1 & 2. See Figure 4 for bolt hole location.
3. Clean the area where the bracket is to be installed. Remove the peel and release paper from both bases, apply a generous amount of sealant around and under the bracket base and screw holes to form a water tight seal then align and install the bracket per note 1. See Figures 3 & 4.

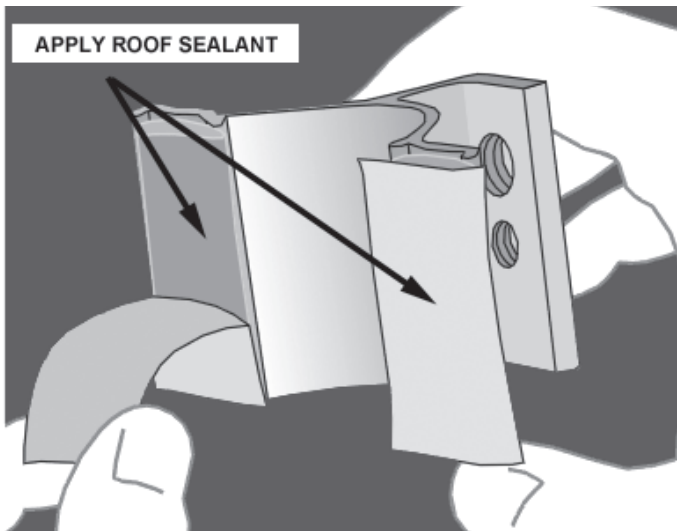

Figure 3.

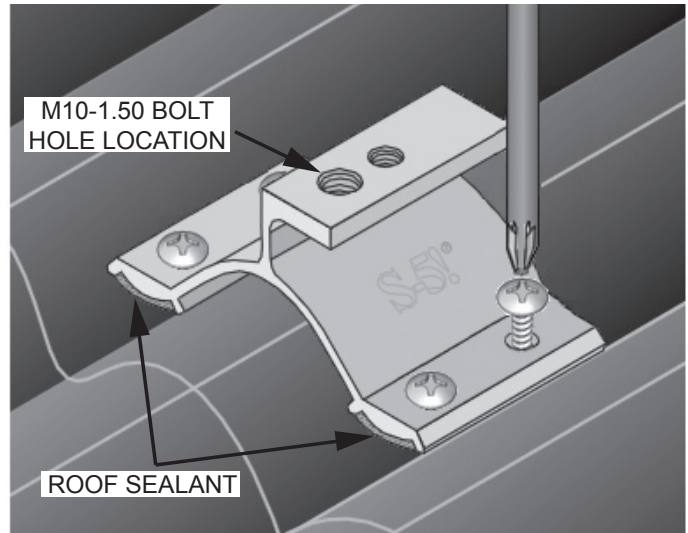

Figure 4.

4. Attach the corrugated metal roof bracket to the supporting roof structure with the included #14 x 3" OMG heavy duty roof fasteners. If a longer fastener is required, use only OMG brand or equivalent. In some cases, a pilot hole of the proper size may be required to install the fastener. Alternate from side to side when installing and tightening the fasteners. See Figure 4.
5. Install the solar collector mounting bracket to the corrugated metal roof bracket with the included M10-1.50 x 1" SS hex bolt. See Figure 5.

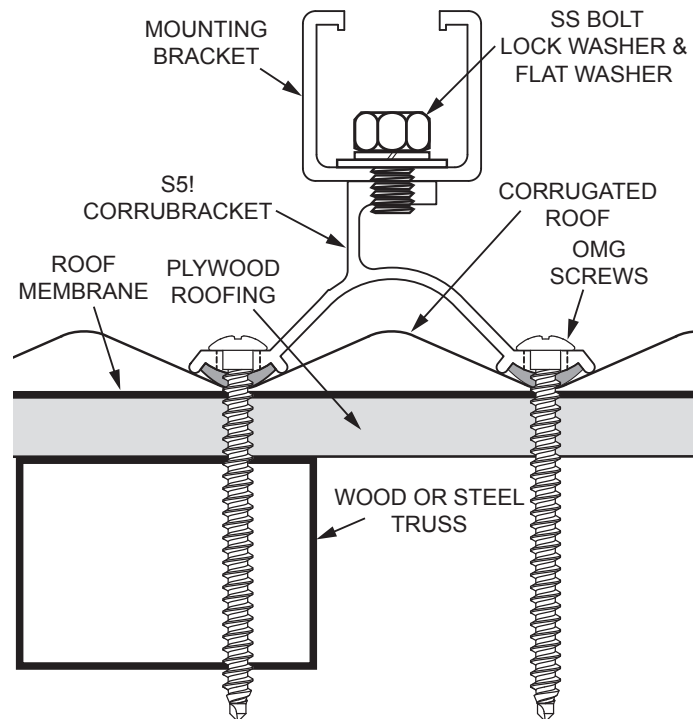

Figure 5.

6. Repeat steps 2-5 for the remainder of the corrugated metal roof mounting bracket locations.

ATTACHING COLLECTOR TO MOUNTING BRACKETS

Once all of the mounting brackets have been secured to the roof the solar collector(s) can be installed. See Figure 6 for these instructions.

1. Insert the stainless steel channel nut w/spring inside of the mounting bracket.
2. Fasten the solar collector mounting clip to the channel nut with the stainless steel bolt, lock-washer, and flat washer as shown. Do not tighten. Repeat step for the other mounting bracket locations.
3. The solar collector can now be set on the mounting brackets. To aid in handling the collectors on the roof the mounting clips may be tightened to the lower mounting brackets prior to raising the collectors. The collector can then be set on the lower mounting brackets while the top clips are fastened over the lip on the collector frame.
4. After the solar collector is in position, locate the upper mounting clip so that its lip over-hangs the lip of the solar collector frame as shown. Tighten the mounting clip to the solar collector frame securely. Repeat for the other upper mounting clips.
5. Once the upper mounting clips are secured, the bottom mounting clips can be loosened and retightened over the collector lip as directed in step 4.
6. Repeat steps as needed for other solar collectors.

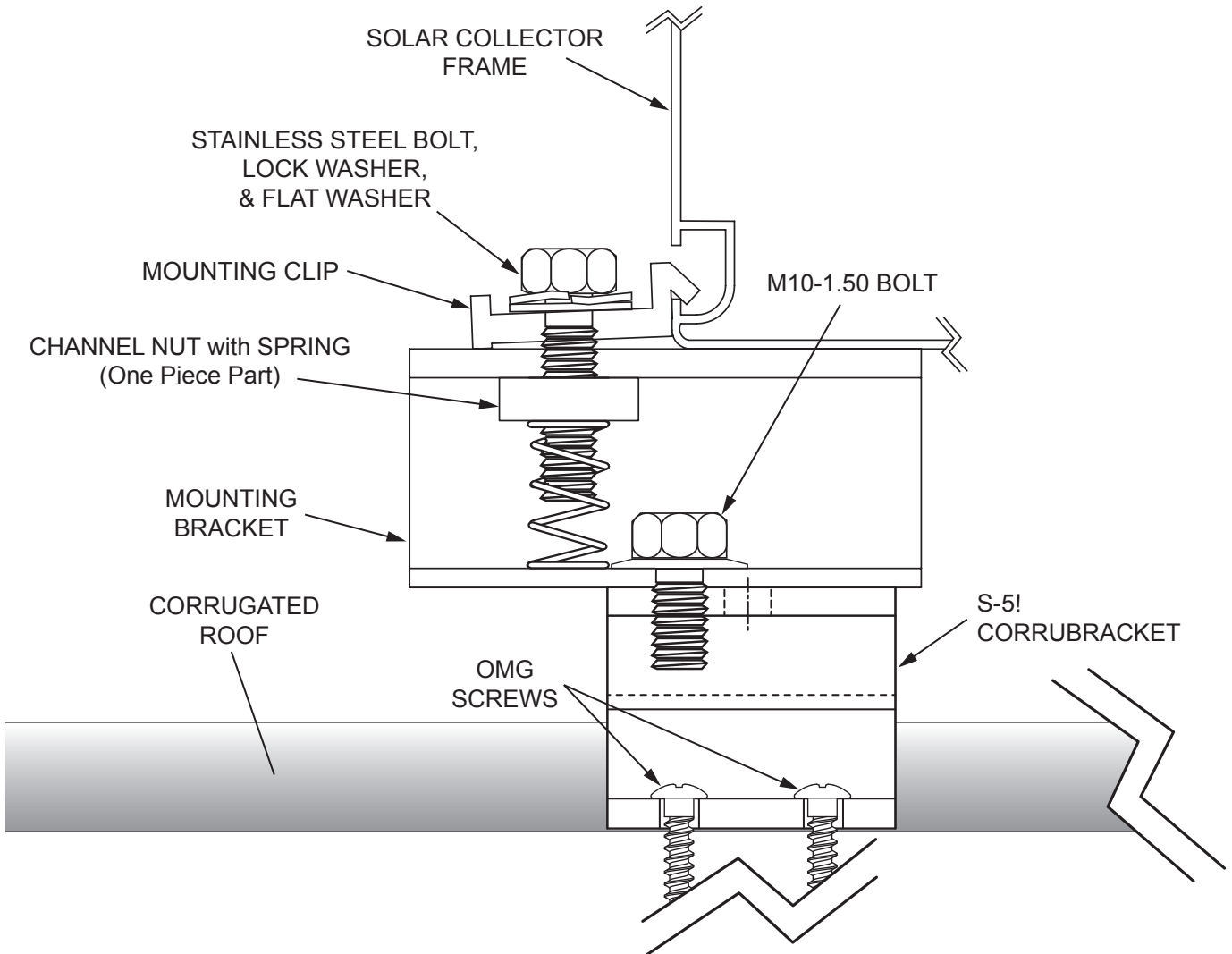

Figure 6.