

## AP Solar Collector Low Pitched Roof Frame Kit

The components contained in this package combine with the AP solar collector's standard frame to form the complete low pitched roof frame shown below.

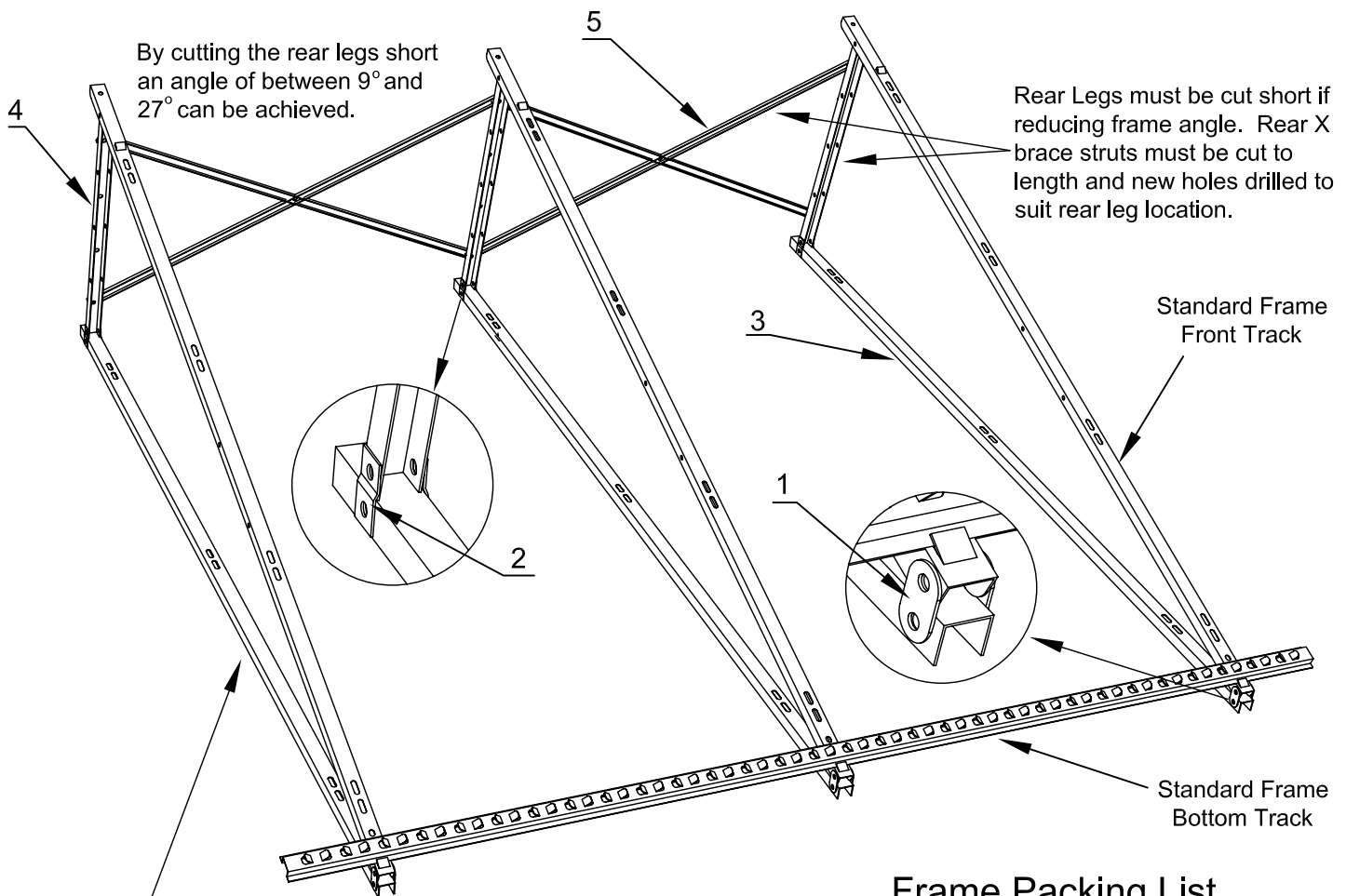

### Frame Packing List

Component Name	Component Quantities	
	10,18 & 20 Tube	22 & 30 Tube
1. Front Connector	4	6
2. Rear Connector	4	6
3. Roof Track	2	3
4. Rear Leg	2	3
5. Rear X Brace	2	4
6. M8x50 Bolt	10	15
7. M8x40 Bolt	0	2
8. M8x20 Bolt	5	6
9. M8 Nut	25	38
10. Washer	25	38
11. Nut Lock	5	8
12. 12/14mm Spanner	1	1

Nuts and bolts are already attached to the appropriate components.

#### **SAFETY CONSIDERATIONS**

- Wear gloves when handling frame components
- If installing on corrugated iron roofs, always use rubber pads, thus preventing direct contact between galvanised iron and stainless steel frame.
- Ensure roof attachment points are structurally sound
- Follow relevant safety regulations regarding working on roofs