

## SUBMITTAL DATA

JOB/CUSTOMER:	SUBMITTED BY:
ENGINEER:	APPROVED BY:
CONTRACTOR:	ORDER NO:
SPECIFICATION REF:	



## NOMENCLATURE

<b>W</b>	.....	Wireless
<b>MS</b>	.....	Motion Sensor
<b>RB</b>	.....	Round Beam
<b>KIT</b>	.....	(1 Receiver & 1 Motion Sensor)

## DESCRIPTION

With the WMSRB-KIT, the user activates the pump by passing through the beam emitted by the motion sensor. The motion sensor sends a signal back to the receiver, which is connected to the pump via a low voltage cable. Kit Includes: one (1) Receiver & one (1) Wireless Motion Sensor (battery operated)

## TECHNICAL DATA

- OPERATING RANGE** 250 feet
- FREQUENCY** 315 MHZ
- WIRING** Three Wire, 12 volt power supply
- DIRECTIONAL PATTERN** Round Beam 20' Range

## APPLICATIONS

Works with the C3-100, S3-100, and the BR3-200  
Indoor use only

The WMSRB-KIT is expandable and up to ten (10) total motion sensors may be added to the receiver. (WMSRB)

The WMSRB-KIT WILL NOT OPERATE in conjunction with Models: WRT-KIT, WT

## DIMENSIONS

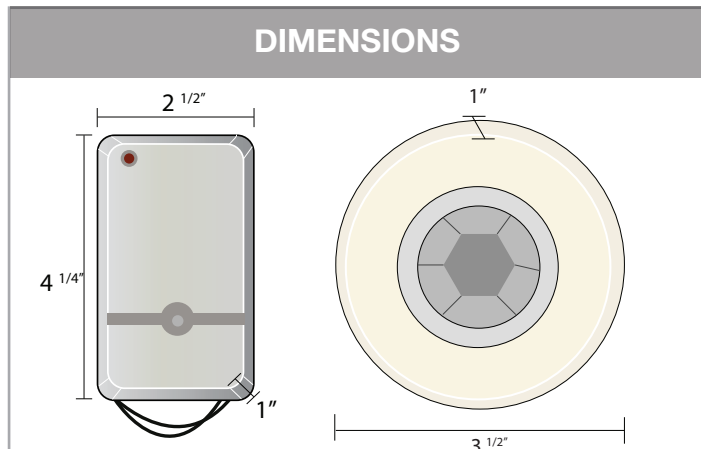

## WARRANTY

Accessories: Hard-Wired Buttons, Wireless Transmitters and Receivers, all Hard-Wired or Wireless Motion Sensors and Receivers: Warranty – (One Year from date of purchase) Labor is not included with Limited Warranty. In order to obtain services under this warranty, it is the responsibility of the purchaser to promptly notify the Company in writing and promptly deliver the item in question, delivery prepaid to the factory. The address for notification and delivery is ACT, Inc. D'MAND KONTROL® Systems, 3176 Pullman Street, Suite 119, Costa Mesa CA 92626. If the product or part in question contains no defects as covered in the warranty, the purchaser will be notified and billed for parts and labor charges in effect at the time of factory examination and repair.