

## SUBMITTAL DATA

JOB/CUSTOMER:

SUBMITTED BY:

ENGINEER:

APPROVED BY:

CONTRACTOR:

ORDER NO:

SPECIFICATION REF:



## NOMENCLATURE

**FL** ..... Flange  
**KIT** ..... Two Custom 3/4" MIP Flanges, 4 nuts & Bolts

## DESCRIPTION

The FL-KIT is a standard flange kit to install all the BR3-200 and the S3-100 units. The Flanges are composed of stainless steel and utilize a 3/4" MIP pipe thread on each side of the pump. The FL-KIT also complies with CA AB1953 no lead standards. 7/16" bolts/nuts are included to tighten the flange to the pump system along with a rubber seal. (included)

## DIMENSIONS

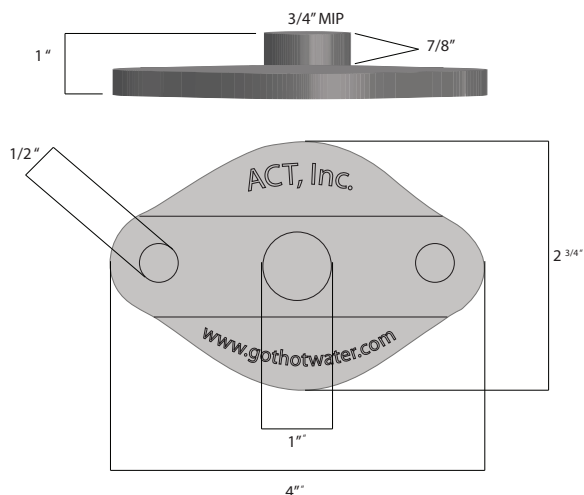

## APPLICATION

Flanges are compatible with ACT, Inc. D'MAND Kontrols® Systems: S3-100, BR3-200 NOT COMPATIBLE with Model C3-100

## WARRANTY

Accessories: Hard-Wired Buttons, Wireless Transmitters and Receivers, all Hard-Wired or Wireless Motion Sensors and Receivers: Warranty – (One Year from date of purchase) Labor is not included with Limited Warranty. In order to obtain services under this warranty, it is the responsibility of the purchaser to promptly notify the Company in writing and promptly deliver the item in question, delivery prepaid to the factory. The address for notification and delivery is ACT, Inc. D'MAND KONTROL® Systems, 3176 Pullman Street, Suite 119, Costa Mesa CA 92626. If the product or part in question contains no defects as covered in the warranty, the purchaser will be notified and billed for parts and labor charges in effect at the time of factory examination and repair.