

Indoor Unit (IDU) measurements in mm.

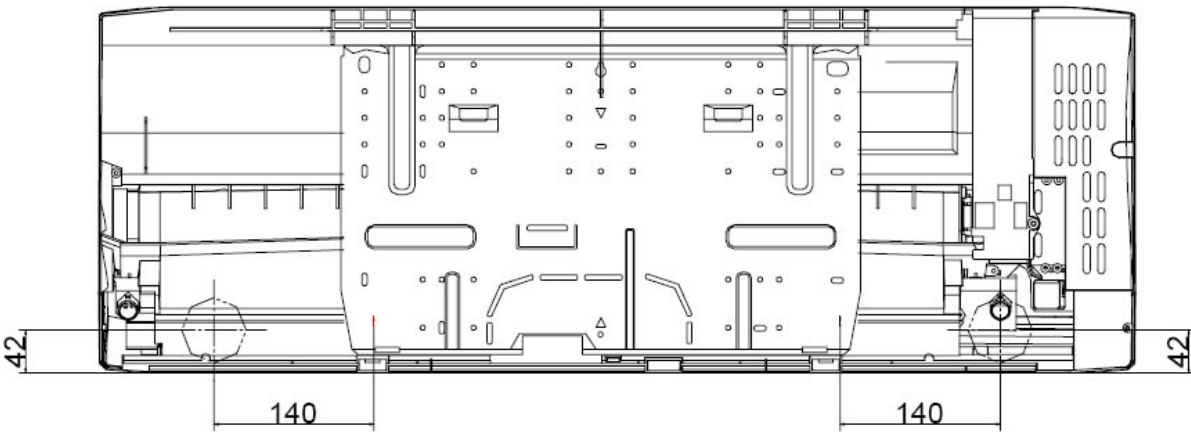

The indoor unit (IDU) connects to the outdoor with control and power connections, and refrigerant line set (all included). The refrigeration line set length is 25 feet, max length = 50 feet. Additional refrigerant charge calculation for extending the length is $= Xg=25g/m*(A-7)m$

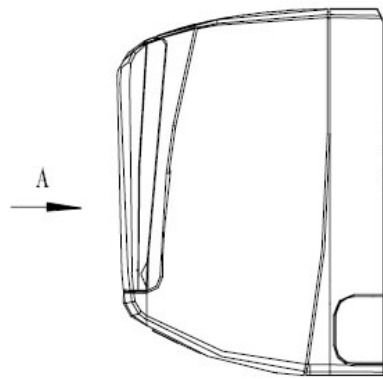
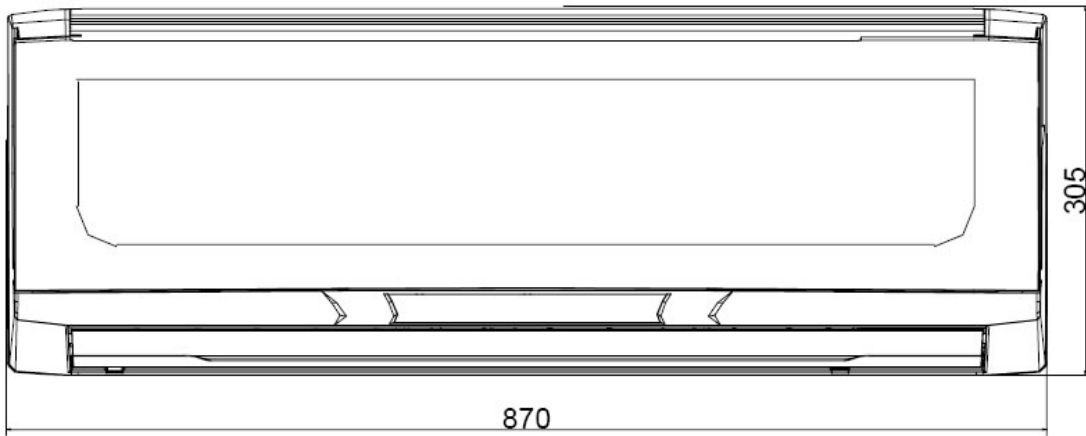
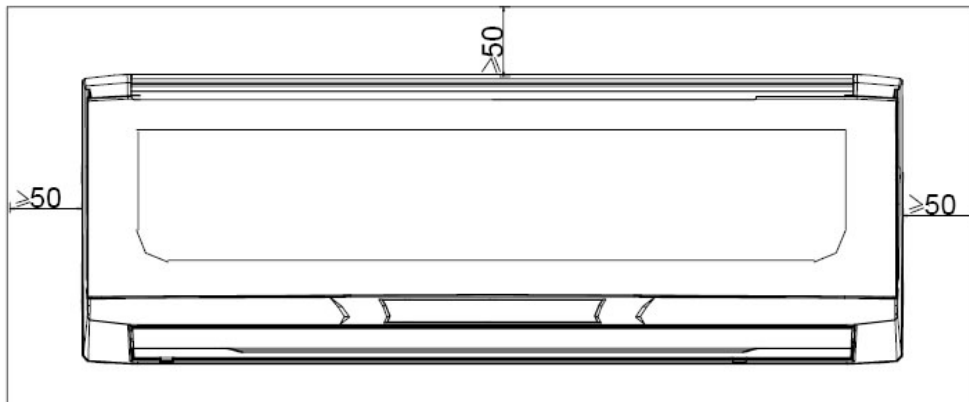

Outdoor Unit (ODU) measurements in mm.

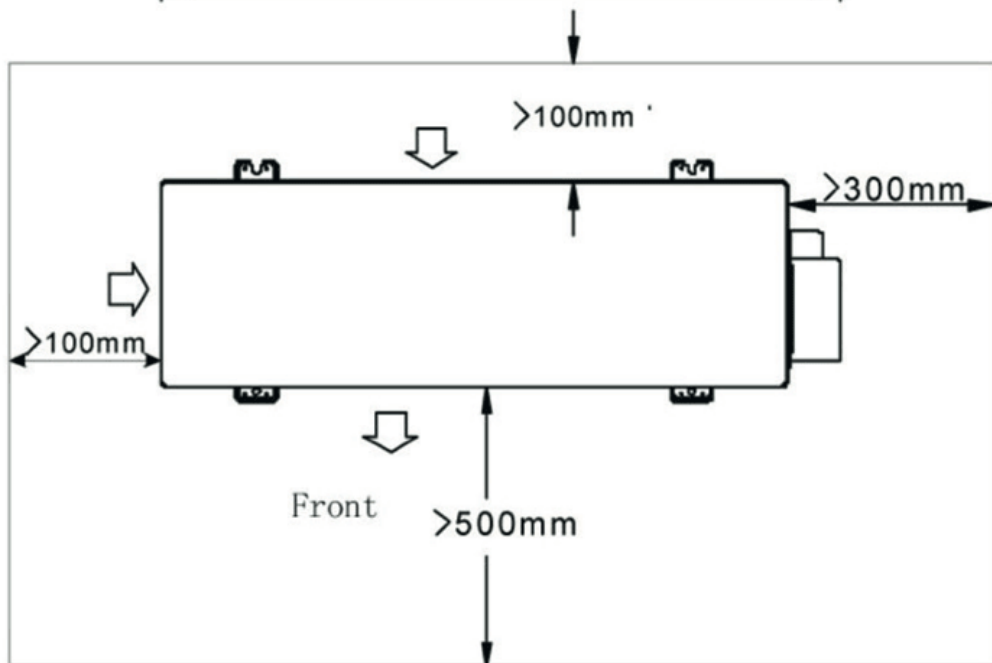
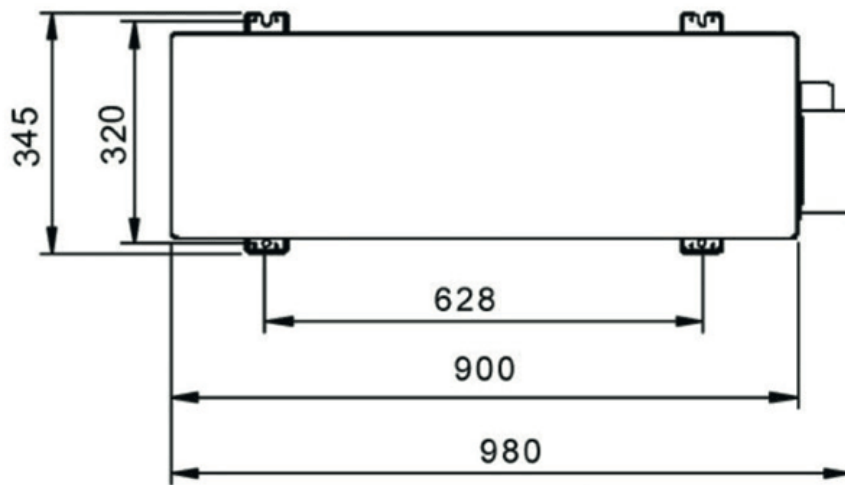
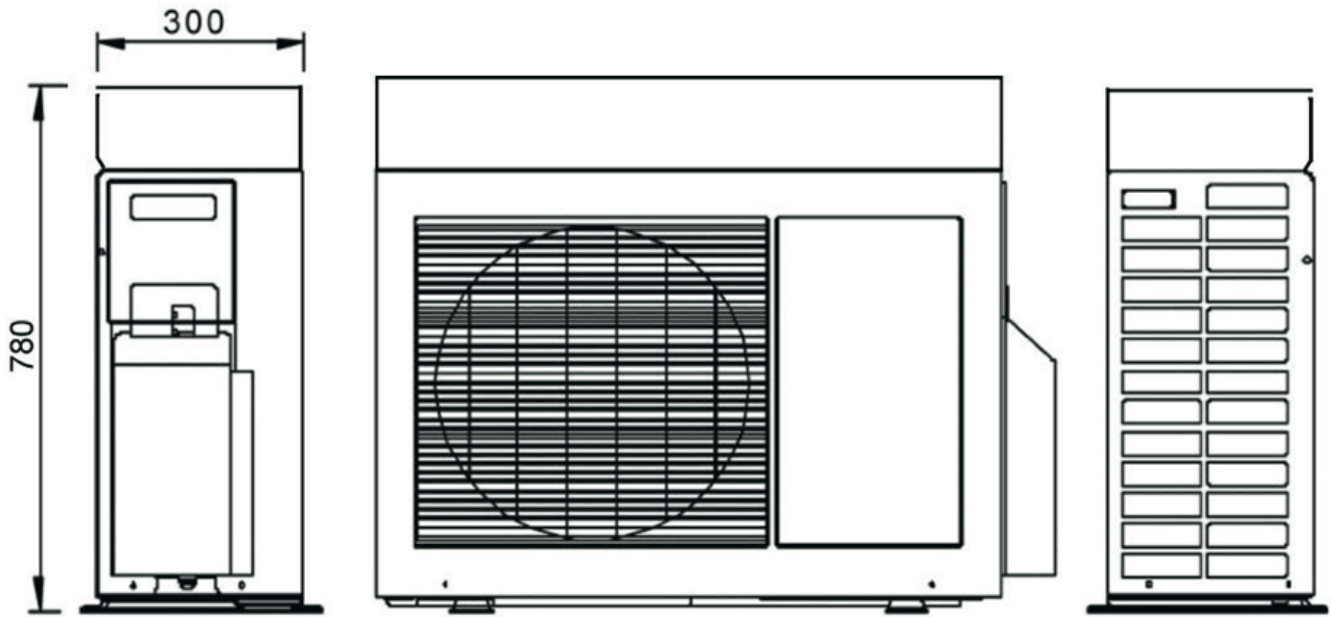

Solar AC Refrigerant Flow Diagram

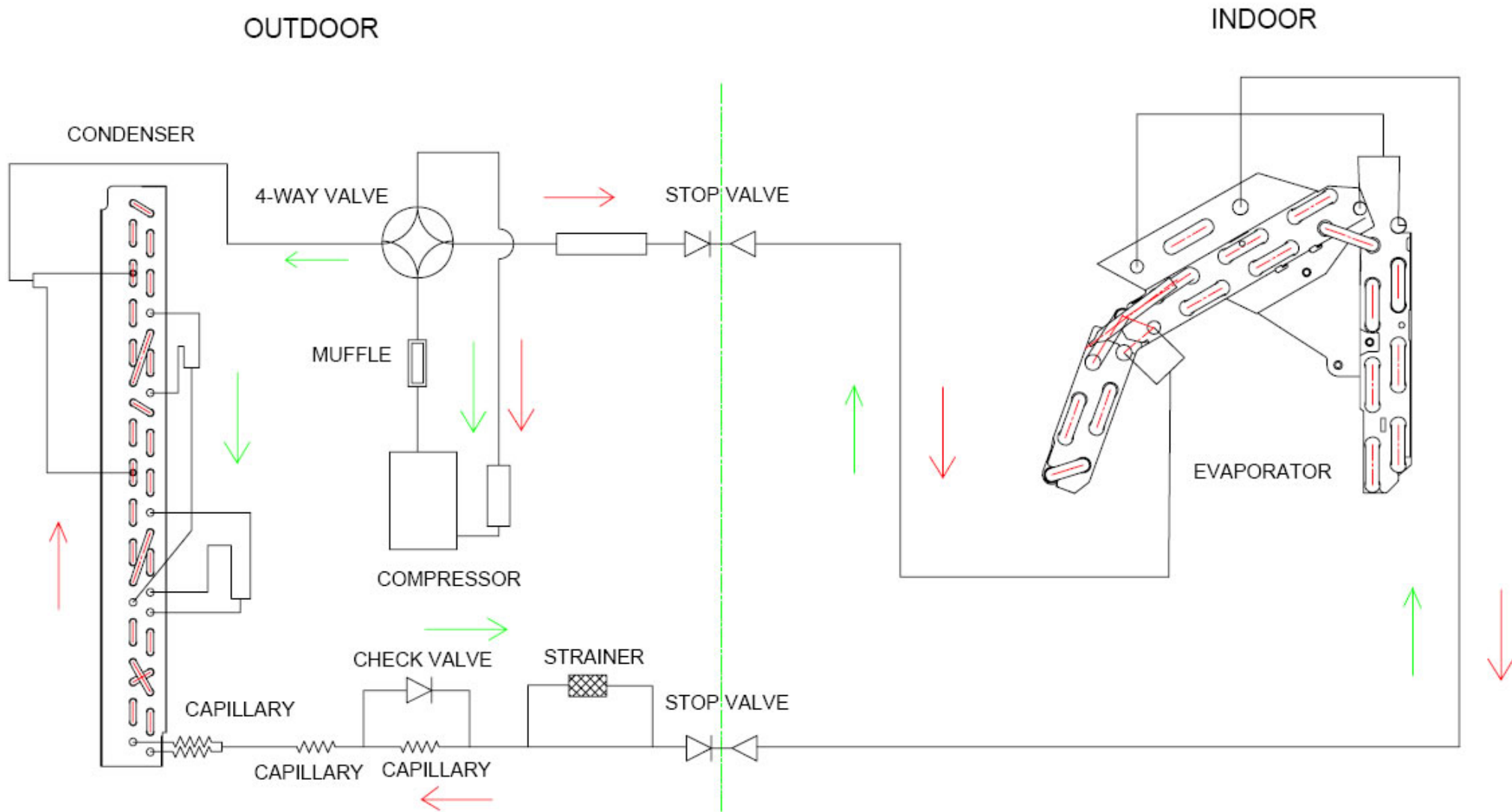

Remark:  **COOLING CYCLE**

Remark:  **HEATING CYCLE**