

# SIEMENS

## Solar module ST20 (Preliminary)



The Siemens ST20 solar (photovoltaic) module converts energy contained in sunlight directly into electricity. It is a solid-state generator that operates silently, without fuel, waste or pollution.

Designed for use in 12 volt systems, the ST20 performs efficiently in all operational conditions. Its distinctive ability to deliver battery-charge power levels in low-light situations makes it particularly effective for specialized applications and in adverse or changeable environments.

### **Siemens advanced PowerMax® thin film technology**

The ST20 module is composed of a monolithic structure of series-connected Copper Indium Diselenide (CIS) based solar cells. These multiple-layer cells, a product of Siemens proprietary material, structure and process technologies, called PowerMax® thin film technology, are characterized by exceptional spectral response and long-term performance integrity. They give the ST20 performance efficiency similar to crystalline photovoltaic modules.

Engineered for durability and ease of use, the ST20 is manufactured under strict quality controls in ISO 9001 certified facilities. A black-anodized aluminum frame secures the glass-front laminate which encapsulates, protects and electrically isolates the solar cells. This rugged construction enables the ST20 to endure even severe environmental events and continue to generate power reliably and efficiently.

Exacting standards of quality plus the proven performance of Siemens advanced photovoltaic technologies, make the ST20 an ideal choice for select commercial and industrial solar systems.

#### **Solar module**

Model:	<b>ST20</b>
Rated Power:	<b>20 Watts</b>
Limited Warranty:	<b>5 Years</b>

## Advanced solar technology

- Proprietary multiple-layer CIS solar cells capture a broad spectrum of light energy to deliver excellent power performance – even in reduced-light or in poor weather conditions.
- A conductive front layer of zinc oxide provides superior light transmission and trapping properties to enhance power output.
- Monolithic interconnected structure of series-connected cells contributes to high reliability.

## Durable construction

- Every module is subject to final factory review, inspection and test to assure compliance with electrical, mechanical and visual criteria.
- Ultra-clear tempered glass front provides excellent light transmission and protects from wind, hail, particle damage and impact.
- Solar cells are laminated between a multi-layered polymer backsheet and layers of ethylene vinyl acetate (EVA) for environmental protection, moisture resistance and electrical isolation.
- Torsion and corrosion resistant anodized-aluminum module frame helps assure dependable performance, even through harsh weather conditions.
- Durable multiple-layered backing system provides the module underside with protection from scratching, cuts, breakage and most environmental conditions.
- Laboratory tested for a wide range of operating conditions.
- Manufactured in ISO 9001 certified facilities to exacting Siemens quality standards.

## Easy installation and use

- Two-conductor, 5' [1.54m], (minimum length), UV stable cable facilitates a variety of mounting schemes and permits easy field wiring.
- Pre-drilled frame mounting holes are strategically positioned for secure and easy installations.
- Uniform flat-black appearance of module and frame is visually compatible with a variety of installation requirements.

## Performance warranty

- 5 Year limited warranty on power output.

Further information on solar products, systems, principles and applications is available in the Siemens Solar product catalog.

Siemens modules are recyclable.

Siemens Solar GmbH  
A joint venture of  
Siemens AG and Bayernwerk AG  
Postfach 46 07 05  
D-80915 München  
Germany  
Tel: 49-89-636-59001  
Fax: 49-89-636-59434

## Solar module ST20 (Preliminary)

Electrical parameters		
Maximum power rating $P_{max}$ [Wp] <sup>1)</sup>		20
Rated current $I_{MPP}$ [A]		1.29
Rated voltage $V_{MPP}$ [V]		15.6
Short circuit current $I_{SC}$ [A]		1.48
Open circuit voltage $V_{OC}$ [V]		21.0

Thermal parameters		
NOCT <sup>2)</sup> [°C]		47±2
Temp. coefficient: short-circuit current		0.26mA / °C
Temp. coefficient: open-circuit voltage		-0.1V/ °C

Qualification test parameters		
Temperature cycling range [°C]		-40 to +85
Maximum system voltage [V]		25.0
Wind Loading PSF [N/m <sup>2</sup> ]		50 [2400]
Maximum distortion <sup>3)</sup> [°]		1.2
Hailstone impact Inches [mm]		1.0 [25]
	MPH [m/s]	52 [v=23]
Weight Pounds [kg]		8.84 [4.1]

- 1) Wp (Watt peak) = Peak power  
(Minimum Wp = 18 Watts)  
Under standard test conditions:  
Air Mass AM = 1.5  
Irradiance E = 1000 W/m<sup>2</sup>  
Cell temperature T<sub>c</sub> = 25 °C
- 2) Normal Operating Cell Temperature at:  
Irradiance E = 800 W/m<sup>2</sup>  
Ambient temperature T<sub>a</sub> = 20 °C  
Wind Speed V<sub>w</sub> = 1 m/s
- 3) Diagonal lifting of module plane.

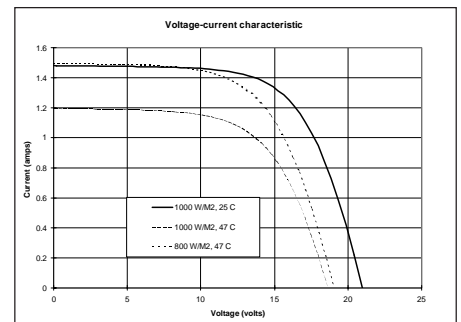

## Module dimensions

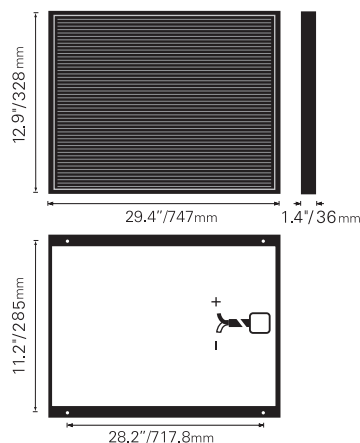

Hole Diameter 0.26 inch (6.6mm)  
Mounting hole dimensions are center to center



Your address for photovoltaics from Siemens Solar

Status 2/99 - Subject to modification. © 1999 Siemens Solar

Siemens Solar Industries

P.O.Box 6032  
Camarillo, CA 93011, U.S.A.  
Tel: 805-482-6800  
Fax: 805-388-6395  
Web site: www.siemenssolar.com  
E-mail: ssi.sales@siemens.solar.com

Siemens Showa Solar Pte. Ltd.

166 Kallang Way  
Singapore 349249  
Tel: 65-842-3886  
Fax: 65-842-3887

Order No. 021344, Rev. A

