



INSTALLATION MANUAL

KD130GX-LP, KD135GX-LP, KD180GX-LP,
KD205GX-LP, KDGX210-LP

SOLAR PHOTOVOLTAIC POWER MODULES

Please read this manual carefully before installing the modules.

1. INTRODUCTION

As the world leader in the development and application of high technology ceramic/silica materials, Kyocera offers a wide range of highly efficient and reliable crystalline silicon solar photovoltaic (PV) power modules. Kyocera began to extensively research PV technology in 1975 and commenced manufacturing operations in 1978. Since then, Kyocera has supplied millions of cells and modules throughout the world. With years of experience and state-of-the-art technology, Kyocera provides the highest quality PV power modules in a range of sizes designed to meet the requirements of the most demanding energy and power users worldwide.

2. APPLICATIONS

KD series modules are a reliable, virtually maintenance-free direct current (DC) power source, designed to operate at the highest level of efficiency. KD series modules are ideal for remote home, water pumping, utility-tied, telecommunications and many other applications either with or without the use of storage batteries.

3. WARNINGS & SAFETY

Solar modules generate electricity when exposed to light. Arrays of many modules can cause lethal shock and burn hazards. Only authorized and trained personnel should have access to these modules. To reduce the risk of electrical shock or burns, modules may be covered with an opaque material during installation. Do not touch live terminals with bare hands. Use insulated tools for electrical connections.

PERMIT

- Before installing your solar system, contact local authorities to determine the necessary permitting, installation and inspection requirements.

INSTALLATION AND OPERATION

- Systems should be installed by qualified personnel only. The system involves electricity, and can be dangerous if the personnel are not familiar with the appropriate safety procedures.
- **Do not step on the module.**
- Although KD series modules are quite rugged, the glass can be broken (and the module will no longer work properly) if it is dropped or hit by tools or other objects.

- Sunlight shall not be concentrated on the module.
- The module frame is made of anodized aluminum, and therefore corrosion can occur if the module is subject to a salt-water environment and is in contact with another type of metal. (Electrolysis Corrosion) If required, PVC or stainless steel washers can be placed between the solar module frame and support structure to prevent this type of corrosion.
- KD series module frame(s) must be attached to a support structure by one of the methods described in Section 6, Installing KD series module(s).
- Module support structures that are to be used to support KD series module(s) should be wind rated and approved for use by the appropriate local and civil codes prior to installation.

FIRE RATING

- KD series modules are comprised of a glass front surface, polyethylene terephthalate (PET) backsheet and possess a Class C fire rating.

GROUNDING

- Refer to "Grounding" section.

INSPECTION

- Follow the requirements of applicable local and national electrical codes.

BATTERY

- When solar modules are used to charge batteries, the battery must be installed in a manner, which will ensure the performance of the system and the safety of its users. **Follow the battery manufacturer's guidelines concerning installation, operation and maintenance recommendations.** In general, the battery (or battery bank) should be away from the main flow of people and animal traffic. Select a battery site that is protected from sunlight, rain, snow, debris, and is well ventilated. Most batteries generate hydrogen gas when charging, which can be explosive. Do not light matches or create sparks near the battery bank. When a battery is installed outdoors, it should be placed in an insulated and ventilated battery case specifically designed for the purpose.

4. SITE SELECTION

In most applications, KD series modules should be installed in a location where they will receive maximum sunlight throughout the year. In the Northern Hemisphere, the modules should typically face south, and in the Southern Hemisphere, the modules should typically face north. Modules facing 30 degrees away from true South (or North) will lose approximately 10 to 15 percent of their power output. If the module faces 60 degrees away from true South (or North), the power loss will be 20 to 30 percent. When choosing a site, avoid trees, buildings or obstructions, which could cast shadows on the solar modules especially during the winter months when the arc of the sun is lowest over the horizon.

5. MODULE TILT ANGLE

KD series modules produce the most power when they are pointed directly at the sun. For stand alone installations the solar modules should be tilted for optimum winter performance. As a general rule, if the system power production is adequate in the winter, it will be satisfactory during the rest of the year. The solar module tilt angle is measured between the solar modules and the ground. Refer to the recommended module tilt angle table for your site.

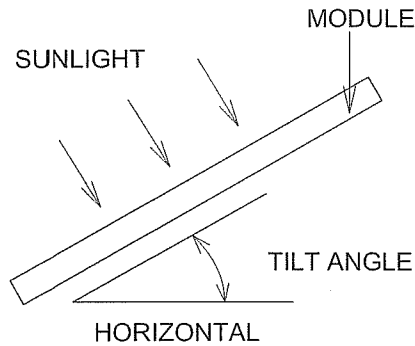

Module Tilt Angle

Recommended Tilt Angles for Stand Alone Fixed Systems—Based on Winter Performance

SITE LATITUDE IN DEGREES	FIXED TILT ANGLE
0° TO 15°	15°
15° TO 25°	SAME AS LATITUDE
25° TO 30°	LATITUDE + 5°
30° TO 35°	LATITUDE + 10°
35° TO 40°	LATITUDE + 15°
40°+	LATITUDE + 20°

For grid tie installations where the solar modules are attached to a permanent structure, the solar modules should be tilted at an angle equal to the site's latitude. This will typically result in the highest annual energy output.

6. INSTALLING KD SERIES MODULES

A minimum gap of 0.6 in. (15 mm) is required between the solar module and the mounting surface. A minimum of .125" (3.2 mm) spacing must also be maintained between module frames to allow for thermal expansion. KD series modules may be installed in various applications utilizing a variety of support structure options and attachment methods. For optimal performance in all applications, a minimum clearance (.6" (15mm)) between the module frame and the mounting surface is required to allow cooler ambient air to circulate between the back of the module and the mounting surface.

BUILDING ATTACHED: The modules are commonly supported parallel to the surface of the building wall or roof. Clearance between the module frames and surface of the wall or roof is required to prevent module and / or wiring

damage. Do not fully enclose the photovoltaic array, as solar modules perform best when cool in temperature. If other mounting means are employed, this may affect the listing for Fire Class Ratings.

FREE STANDING: The supporting structure is used to mount modules at correct tilt angles. The mounting design may have an impact on the fire resistance.

KD series modules may be attached to a support structure by the following methods:

STANDARD: Utilizing ¼" or 6mm stainless steel hardware through the existing 0.28" diameter (7 mm) mounting holes in the module frame and then through KD series module mounting holes on the support structure. The stainless steel hardware used for securing the module frame should be secured with an applied torque of 6 foot-pounds (8 Newton-meters). Refer to the Module Drawings for the position of the solar module mounting holes.

CLAMPING: Top or bottom clamping methods as certified by a registered professional engineer, and in compliance with local codes.

OTHER: Other method(s) certified by a registered professional engineer, and in compliance with local codes.

7. MODULE WIRING

KD series GX modules come pre-wired and terminated ready for most building attached or free standing installations. Each module has two #10 AWG type USE-2/RHH/RHW-2 stranded sunlight resistant output cables each terminated with Multi-Contact® locking connectors. The positive (+) terminal has a male connector while the negative (-) terminal has a female connector. The module wiring is solely for series connections only, i.e. male (+) to female (-) interconnections. Series and parallel connections shall be made by use of two #10 AWG type XLP sunlight resistant output cables with male and female Multi-Contact® locking connectors.

NOTE: When making connections with Multi-Contact connectors, make sure the array is disabled. **DO NOT MAKE CONNECTIONS WHILE UNDER LOAD.** Module output connections are marked "Do not disconnect under load".

NOTE: MAXIMUM SYSTEM VOLTAGE 600 VDC.

KD series modules and most PV system components have a maximum system voltage rating of 600 volts DC. Some grid-tie systems operate at or near this voltage rating. Like other polycrystalline solar modules, the open circuit voltage of the KD series module increases as the ambient temperature decreases. Maximum System voltage is computed as the sum of the open-circuit voltage of the series-connected photovoltaic modules for the lowest expected ambient temperature. Refer to the National Electrical Code Article 690-7(a) for determining the maximum number of KD series modules that can be placed in series. Temperature coefficients, specific to the module of use, can be used to provide the most accurate prediction of module voltage under temperature extremes.

8. GROUNDING

Before installation, contact the local code authorities to determine the necessary grounding requirements. Attach all module frames to an earth ground in accordance with the National Electric Code (NEC) Article 250. Proper grounding is achieved by connecting the module frames and all metallic structural members contiguously to one another using a suitable grounding conductor. The grounding conductor shall be of copper, copper alloy or another material suitable for use as an electrical conductor per NEC. The grounding conductor must then make a connection to earth using a suitable earth grounding electrode. Ensure positive electrical contact through the anodizing on the module frame extrusion utilizing one of the following methods. Attach the grounding conductor:

- (1) to one of the .28" (7mm) diameter holes marked "ground" using ¼" stainless steel bolt, stainless steel star washer, cup washer, stainless steel flat-washer, stainless steel star washer, and stainless steel nut. Wrap conductor around bolt. Avoid direct contact of copper ground conductor to aluminum frame.
- (2) to a listed, outdoor or direct burial rated ground lug. Use 10-32 stainless steel hardware to attach the lug to the module frame. A stainless steel star washer, positioned between the lug and the anodized surface of the frame, must be employed to break through the anodized layer of the frame extrusion and electrically connect the ground lug to the conducting aluminum frame material.

As a general rule, avoid *direct* contact of copper or copper alloyed ground conductors with the aluminum module frame. All ground bond securing hardware in contact with either the aluminum module frame and/ or copper or copper alloy ground conductors must be stainless steel.

9. BLOCKING DIODES

In systems utilizing a battery, blocking diodes are typically placed between the battery and the solar module output to prevent battery discharge at night. KD series modules are made of polycrystalline cells with high electrical "back flow" resistance to nighttime battery discharging. As a result, KD series modules do not contain a blocking diode when shipped from the factory. Most PV charge regulators and inverters incorporate nighttime disconnect feature, however.

10. BYPASS DIODES

Partial shading of an individual module in a source circuit string (i.e. two or more modules connected in series) can cause a reverse voltage across the shaded cells within the module. Module output current is then forced through the shaded area by the remaining illuminated cells and other solar modules in series with the partially shaded module(s). The current forced through the shaded cells within the module (or modules) causes additional module heating and severe loss of power. All KD series GX modules are supplied with factory installed (non user serviceable) bypass diodes.

The purpose of bypass diodes is to provide a low-resistance current path around the shaded cells, thereby minimizing module heating and array current losses.

The solar modules employ bypass diodes that have:

- Rated Average Forward Current [$I_{F(AV)}$] **Above** maximum system current at highest module operating temperature.
- Rated Repetitive Peak Reverse Voltage [V_{RRM}] **Above** maximum system voltage at lowest module operating temperature.

11. MAINTENANCE

KD series modules are designed for long life and require very little maintenance. Under most weather conditions, normal rainfall is sufficient to keep the module glass surface clean. If dirt build-up becomes excessive, clean the glass surface only with a soft cloth using mild detergent and water. **USE CAUTION WHEN CLEANING THE BACK SURFACE OF THE MODULE TO AVOID PENETRATING BACK SHEET.** Modules that are mounted flat (0° tilt angle) should be cleaned more often, as they will not "self clean" as effectively as modules mounted at a 15° tilt or greater. Once a year, check the general condition of the wiring and check to be sure that mounting hardware is tight. Loose connections may result in a damaged module or array.

KYOCERA Solar Group Sales Office

■ KYOCERA Corporation

Corporate Solar Energy Group
6 Takeda Tobadono-cho Fushimi-ku, Kyoto 612-8501,
Japan
Phone : 81-75-604-3476
Fax : 81-75-604-3475
<http://www.kyocera.com/>

■ KYOCERA Solar Inc.

7812 East Acoma Drive, Scottsdale, AZ 85260, U.S.A.
Phone : 1-480-948-8003 or 1-800-223-9580
Fax : 1-480-483-6431
<http://www.kyocerasolar.com/>

■ KYOCERA Solar Pty Ltd.

Level 3, 6-10 Talavera Road
North Ryde NSW 2113, Australia
Phone : 61-2-9870-3948
Fax : 61-2-9888-9588
<http://www.kyocerasolar.com.au/>

■ KYOCERA Solar do Brasil Ltda.

Av. Guignard 661, Loja A
Recreio dos Bandeirantes-Rio de Janeiro, 22790-200, Brazil
Phone: 55-21-2437-8525 Fax: 55-21-2437-2338
<http://www.kyocerasolar.com.br/>

■ KYOCERA Fineceramics GmbH

Fritz Müller Strasse 107, D-73730 Esslingen, Germany
Phone : 49-711-93934-999
Fax : 49-711-93934-950
<http://www.kyocerasolar.eu/>

■ KYOCERA Asia Pacific Pte Ltd.

298 Tiong Bahru Road, #13-03/05 Central Plaza
Singapore 168730
Phone : 65-271-0500
Fax : 65-271-0600
<http://www.kyocera.com.sg/>

■ KYOCERA (Tianjin) Sales & Trading Corp.

Room 2107, Ruoyi Chai Building, No.8
Yong An Dong Li, Jian Guo Men Wai Road,
Chao Yang District, Beijing 100022, China
Phone: 86-10-8528-8838 Fax: 86-10-8528-8839

12. SPECIFICATIONS

- Typical module production may result in a maximum power from 5% higher to 5% lower than Rated Power (Pmax). Under certain conditions, a photovoltaic module may produce more voltage and current than reported at Standard Test Conditions (STC). Refer to Section 690 of the National Electrical Code for guidance in series string sizing and choosing overcurrent protection.

Kyocera KD Series Module Specification

Electrical Characteristics: @ STC					
Module Type	KD130GX-LP	KD135GX-LP	KD180GX-LP	KD205GX-LP	KD210GX-LP
Pmax	130W	135W	180W	205W	210W
Voc	22.1V	22.1V	29.5V	33.2V	33.2V
Isc	8.06A	8.37A	8.35A	8.36A	8.58A
Vpm	17.7V	17.7V	23.6V	26.6V	26.6V
Ipm	7.35A	7.63A	7.63A	7.71A	7.90A
Factory installed Bypass Diode (QTY)	2 ea	2 ea	3 ea	3 ea	3 ea
Series Fuse Rating (A)	15	15	15	15	15
Thermal Characteristics: Temp. Coefficient					
Temp. coefficient of Voc (V/°C)	-0.80×10^{-1}	-0.80×10^{-1}	-1.06×10^{-1}	-1.20×10^{-1}	-1.20×10^{-1}
Temp. coefficient of Isc (A/°C)	4.83×10^{-3}	5.02×10^{-3}	5.01×10^{-3}	5.02×10^{-3}	5.15×10^{-3}
Temp. coefficient of Vpm (V/°C)	-0.91×10^{-1}	-0.91×10^{-1}	-1.21×10^{-1}	-1.37×10^{-1}	-1.37×10^{-1}
Physical Characteristics:					
Module Type	KD130GX-L P	KD135GX-LP	KD180GX-LP	KD205GX-LP	KD210GX-LP
Length, Inches(mm)	59.1 (1500)	59.1 (1500)	52.8 (1341)	59.1 (1500)	59.1 (1500)
Width, Inches(mm)	26.3 (668)	26.3 (668)	39.0 (990)	39.0 (990)	39.0 (990)
Depth, Inches(mm)	1.4 (36)	1.4 (36)	1.4 (36)	1.4 (36)	1.4 (36)
Weight, Pounds(kg)	28.7 (13.0)	28.7 (13.0)	36.4 (16.5)	40.8 (18.5)	40.8 (18.5)
Mounting Hole inches(mm)	0.28"(7) Quantity 4 ea				
Grounding Hole Diameter inches (mm)	0.28"(7) Quantity 4 ea				

NOTES

- Standard Test Conditions of irradiance of 1000 W/m², spectrum of 1.5 air mass, and cell temperature of 25 deg C.
- Nominal Operating Cell Temperature (NOCT) of 800 W/m², spectrum of 1.5 air mass, and cell temperature of 20 deg C.
- See module drawing for mounting and grounding hole locations.

