

ES-A Series Photovoltaic Panels

Mounting Guide (including PanelClaw™)

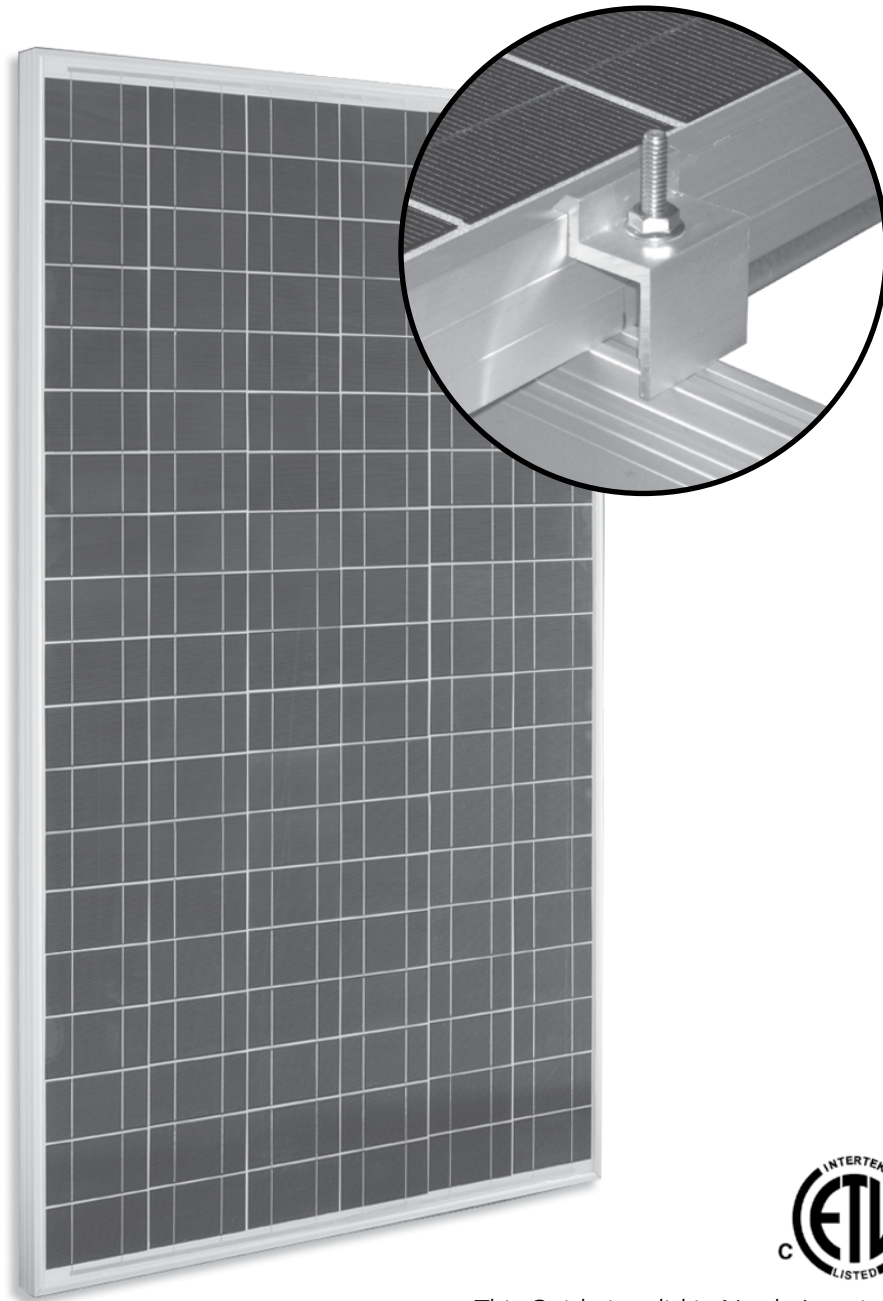

*This Guide is valid in North America only
(ETL listed; conforms to UL Standard 1703)*

PanelClaw™ is a trademark of PanelClaw, Inc.



ELECTRICAL EQUIPMENT — CHECK WITH YOUR INSTALLER

Evergreen Solar ES-A Series photovoltaic (PV, solar electric) panels are designed to produce DC electrical energy from light. This manual contains important installation information with which you should be familiar before using Evergreen Solar panels.



ES-A Series Photovoltaic Panels

Mounting Guide

Due to continuous innovation, research and product development, the guidelines in this Mounting Guide are subject to change without notice. No rights can be derived from the Mounting Guide and Evergreen Solar assumes no liability whatsoever connected to or resulting from the use of any information contained herein.

Introduction

This guide is designed to make using Evergreen Solar panels as easy as possible by providing a comprehensive range of installation options.

It is also designed to give you clear instructions on how to install Evergreen Solar panels to ensure compliance with all major certification and regulatory requirements as well as Evergreen Solar warranty requirements.

All guidelines in this document apply to ES-A Series products manufactured by Evergreen Solar. They do not apply to any other products manufactured by Evergreen Solar or any product manufactured by another company. ES-A Series products not installed according to these guidelines will void the warranty.

Two major methods of mounting ES-A Series solar panels are described in this guide:

Method A: Support rails or support points located symmetrically under the panel

Method B: Independent support points located asymmetrically under the panel

Each method has several permissible configurations, which are all described in detail. Each configuration has a maximum combined wind and snow loading associated with it that is guaranteed by Evergreen Solar. Panels can be mounted in either a horizontal or vertical orientation providing one of the approved mounting methods is used.

The mounting system vendors' installation instructions must always be strictly followed and in cases where the mounting system vendor either:

- a) Does not allow a particular configuration which is permissible according to this guide, or
- b) Does not allow wind or snow loads as high as described in this guide,

Then the mounting vendors' installation instructions must take precedence over these guidelines. In any cases of doubt the mounting vendors' installation instructions should always take precedence.

In addition, you should always consult with your local authorities for stricter regulations which may apply in your particular area or to the particular structure you are attaching Evergreen Solar panels to.

For additional information please read the Safety, Installation and Operation Manual provided by Evergreen Solar and available upon request.

We wish you every success in using Evergreen Solar product.

Worldwide Headquarters

Evergreen Solar Inc.
138 Bartlett Street
Marlboro, MA 01752 USA
T: +1 508.357.2221
F: +1 508.229.0747
info@evergreensolar.com



www.evergreensolar.com

Customer Service - Americas and Asia

Evergreen Solar Inc.
138 Bartlett Street
Marlboro, MA 01752 USA
T: +1 508.357.2221
F: +1 508.229.0747
sales@evergreensolar.com

ES-A Series Photovoltaic Panels

Mounting Guide

Mounting Method A

Support rails or support points located symmetrically under the panel

Configuration Options

Two symmetrical mounting configurations are permissible: end mounting and offset mounting. End mounting (Figure 1) uses two support rails installed under the outer edges of the panel frame (on the short sides) that run flush along the entire panel width.

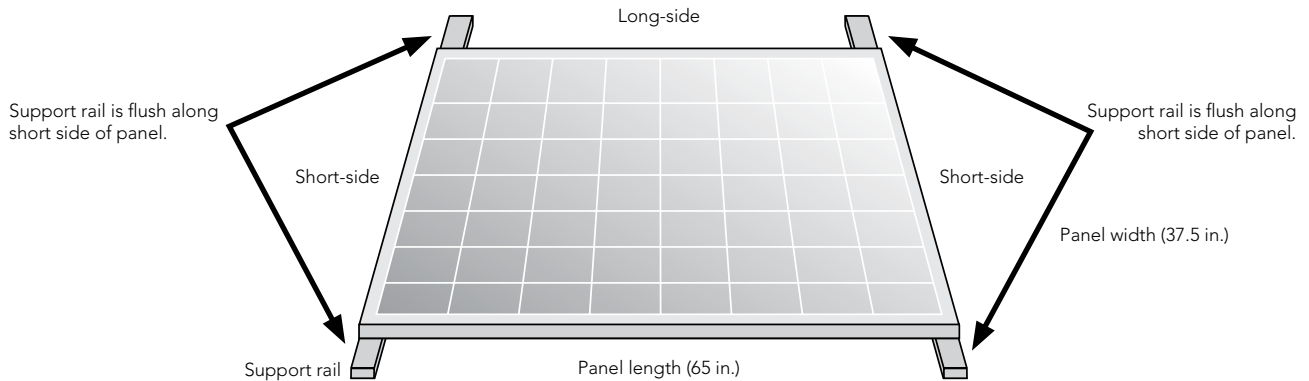

Figure 1: End Mounting

Offset mounting (Figure 2) uses two support rails installed under the main span of the panel and extending across the entire panel width.

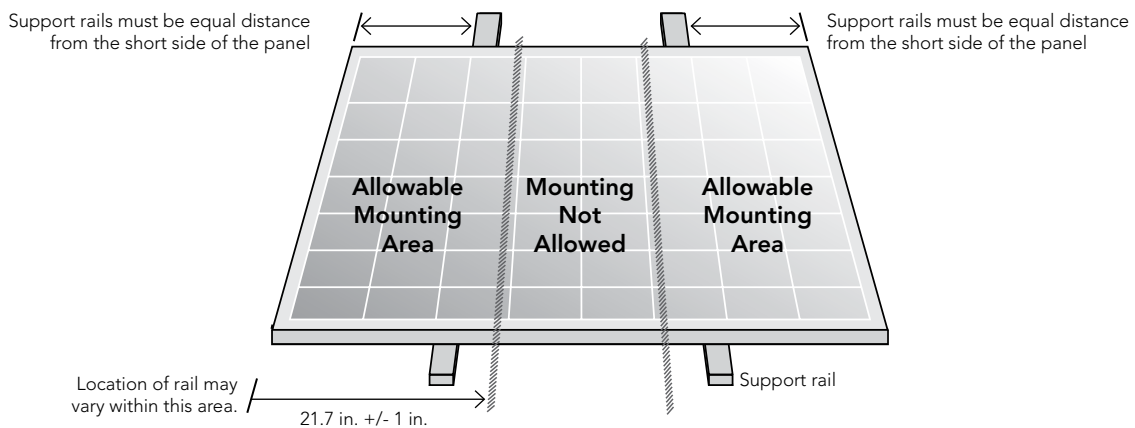

Figure 2: Offset Mounting

For offset mounting, both rails must be located inside the allowable mounting areas indicated in Figure 2 (i.e. within 21.7 in. of each short-side edge of the panel). One rail must lie under each half of the panel and both rails must be the same distance from the corresponding short-side of the panel. The following sections describe each mounting configuration in more detail.

ES-A Series Photovoltaic Panels

Mounting Guide

End Mounting

The end mounting method is guaranteed to a maximum combined wind and snow load of **40 lbs/ft²**. Three end mounting options are permissible as detailed below:

Option #1 – Rigid Rail Supports

Rigid rails spanning the entire panel width must support the short-sides of the panel. The rail area directly in contact with the panel frame must be at least $\frac{3}{4}$ in. wide. Topside clamps must be used to secure the panel in place and must overlap at least $\frac{1}{5}$ in. of the frame top surface. Three different topside clamp configurations may be used as follows:

Clamp Arrangement #1a

The short sides of the panel may be clamped along the entire frame top surface as shown in Figure 3.

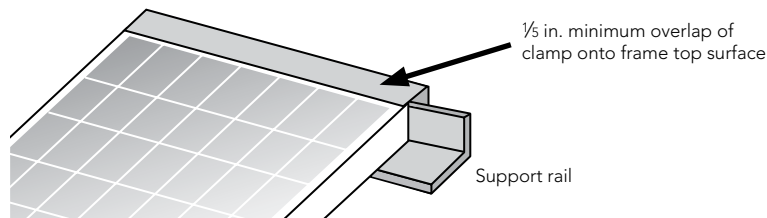

Figure 3: Clamping along the complete length of the panel short-side

Clamp Arrangement #1b

The short sides of the panel may be clamped at the corners using a top-side clamp shared by adjacent panels. Since Evergreen Solar recommends a minimum $\frac{1}{4}$ in. gap between panels, the clamp should be at least $2\frac{1}{4}$ in. long to ensure each panel frame is clamped by at least 1 in.

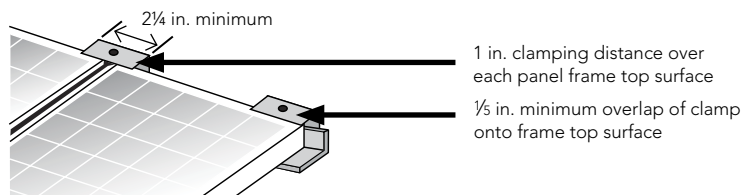

Figure 4: Clamping adjacent panel frames

Clamp Arrangement #1c

The short sides of the panel may be clamped by two top-side clamps which are not shared by adjacent panels. Each clamp must be at least 1 in. long and the entire clamp must be positioned within 3 in. from the nearest panel corner.

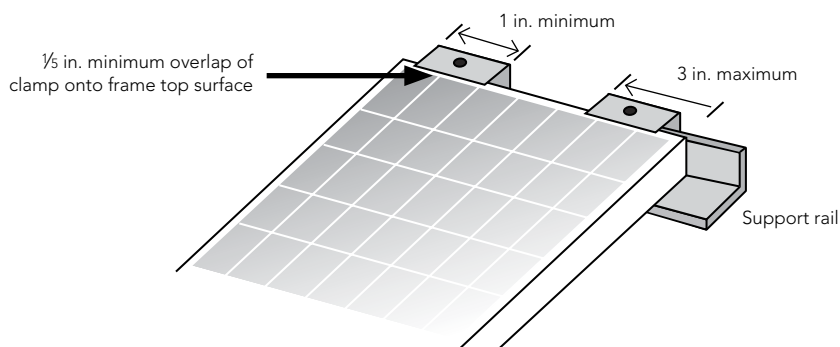

Figure 5: Clamping each panel frame individually

ES-A Series Photovoltaic Panels

Mounting Guide

Option #2 – Clamp-Based Supports Only

The short sides of the panel may also be supported and clamped at each corner without using support rails in direct contact with the frame. Each corner clamp must be at least 1 in. long and clamp both the top and bottom surfaces of the frame over a distance of at least 1 in. The entire clamp must be positioned within 1¾ to 3 in. of the panel corner.

Figure 6: Clamping each panel without rails in direct contact with the panel

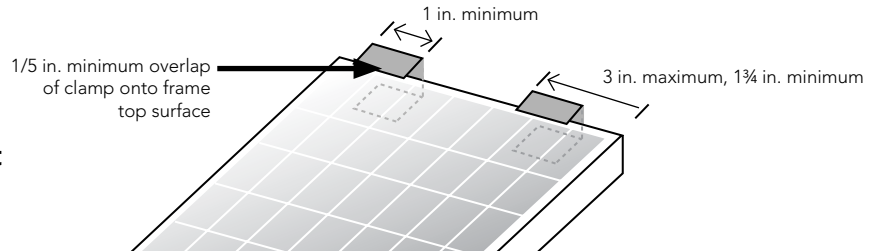

Option #3 - PanelClaw™ attachment system

This method uses a special clamp, called a "claw", designed to attach to the flange of the frame. The claw (P/N 191-001) is manufactured by PanelClaw, Inc. and is exclusively used in their mounting systems. Four claws are required per panel; one on each corner. Place claw over flange and tighten the 3/8-16 x1.25" SHCS 18 – 8 S/S screw between 18 to 20 ft-lb. Ensure the claw is flush with both the long and short lengths of the panel flange as shown in Figure 7.

Figure 7: PanelClaw™ attachment system

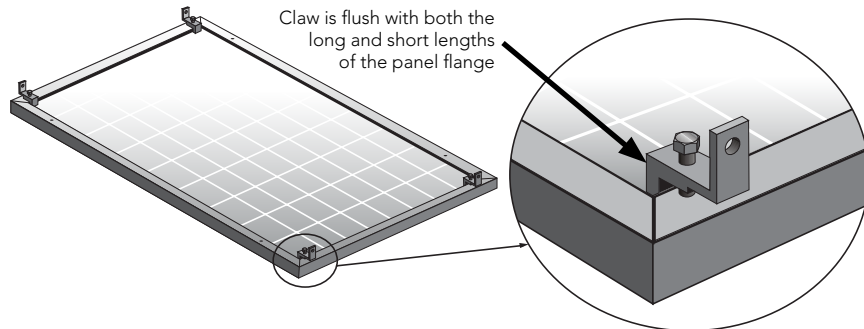

Offset Mounting:

For the offset mounting configuration the first mounting rail – installed on either the left or right side of the panel – must be installed within the allowable mounting area (i.e. within 21.7 in. of each short side edge). The second rail must be located at the same distance from the opposite short edge of the panel.

There are 4 sections (I, II, III and IV) within the allowable mounting area that correspond to different maximum combined wind and snow loads. The location of each section is shown in Figure 8.

Figure 8: The location of different sections in the allowable mounting area

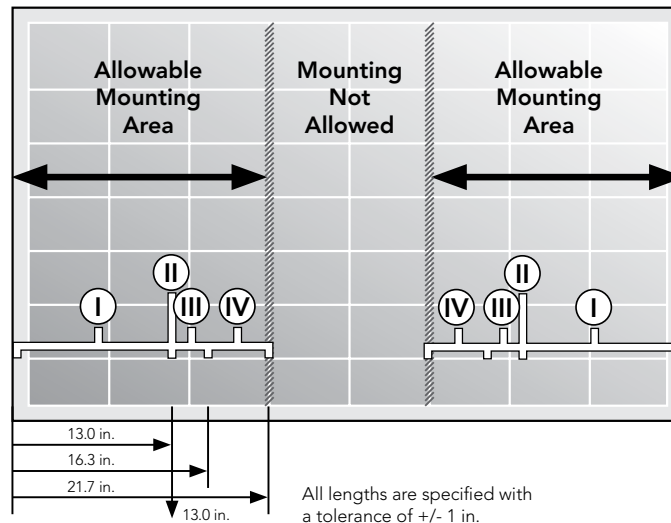

ES-A Series Photovoltaic Panels

Mounting Guide

Offset Mounting continued

Figure 9 illustrates the maximum permissible combined wind and snow loads for sections I, II, III and IV. Support rails at section II allow the highest maximum loading of 60 lbs/ft². Support rails located anywhere in sections I and III allow a maximum of 40 lbs/ft² and 50 lbs/ft² respectively.

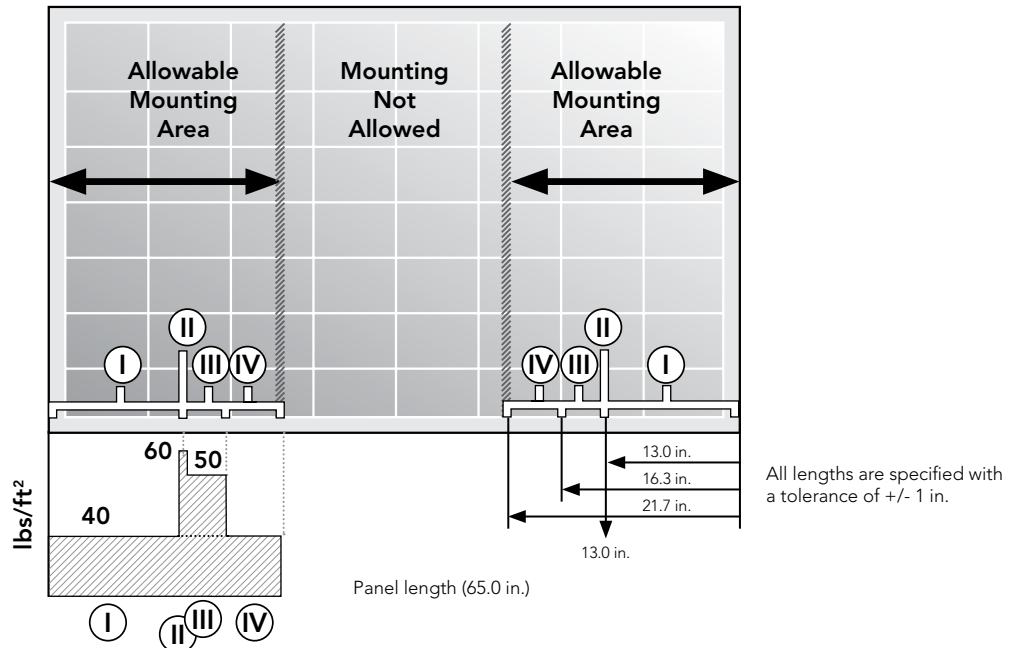

Figure 9: Maximum permissible combined wind and snow loads by rail location

For offset mounting only one clamping configuration is permissible as shown in Figure 10. At least two rigid support rails must span the entire panel width and topside clamps must be used to secure the panel to the rails. Clamps must be at least 1½ in. wide and the rail area supporting the panel must be at least ¾ in. wide.

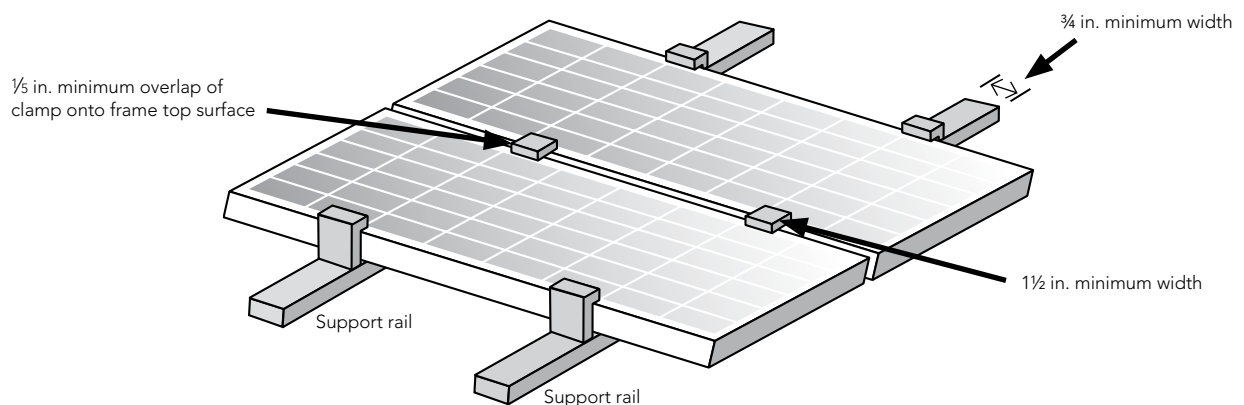

Figure 10: Permissible clamp arrangement for offset mounting

Offset Mounting using the frame holes

Mounting holes with a diameter of ¼ in. are also provided in the panel frame at the 1/5 and 1/4 points. These points are located on the long-sides of the panel at 13.0 in. and 16.3 in. respectively from the short-sides of the panel; all four mounting holes must be used when mounting a panel using the frame holes and the maximum combined wind and snow loadings for offset mounting apply at these locations.

ES-A Series Photovoltaic Panels

Mounting Guide

Mounting Method B

Independent support points located asymmetrically under the panel

Mounting method B uses point supports under the panel frame instead of continuous rails. The point supports can be asymmetrically located under the panel as long as the guidelines detailed below are followed.

The spacing and location of the point supports is designed to allow direct mounting of panels to 24 in.-spaced roof rafters. This mounting method is guaranteed to a maximum combined wind and snow load of **40 lbs/ft²** for any configuration option.

Configuration Options

Two configuration options are permissible – one with four support points per panel and one with six. Each support point must be at least 1½ in. wide (see Figure 11) and must support the entire width of the frame flange (see Figure 12). Top side clamps must be used to secure the panel in place; each top-side clamp must be at least 1½ in. wide, and must overlap at least ½ in. of the frame top surface.

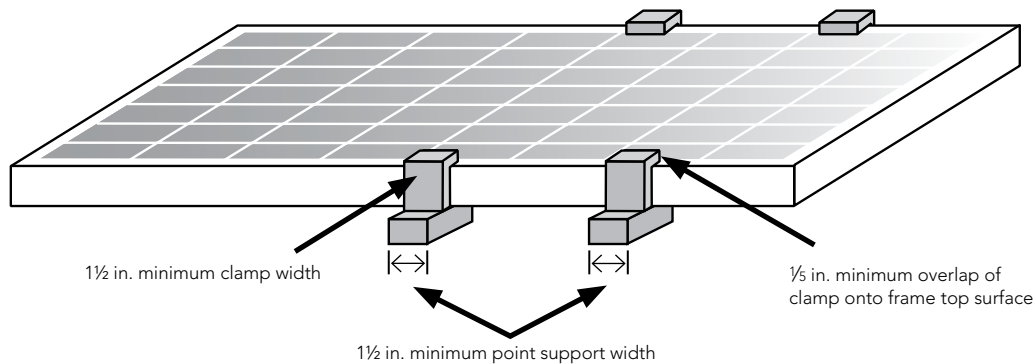

Figure 11: Point support and clamp requirements

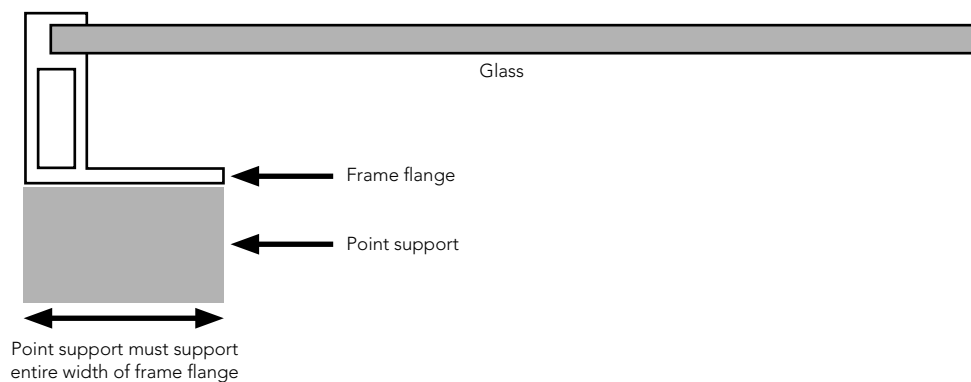

Figure 12: Location of point support in relation to the panel frame

ES-A Series Photovoltaic Panels

Mounting Guide

Option #1 – Four Supports

Four supports can be used to support the panel, positioned as shown in Figure 13. Two supports must be positioned under each half of the panel, and supports on opposite sides of the panel must be in line with each other.

The first set of supports, installed on either the left or right side of the panel, must be installed between 15.5 and 25.5 in. from the short-side edge of the panel. The second set of supports must be located at a distance of 24 in. (+/- 1 in.) from the first set of supports.

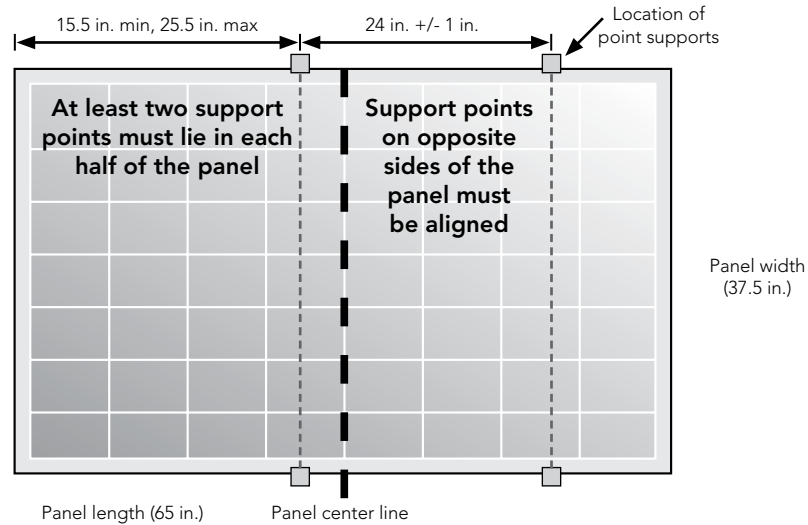

Figure 13:
Required support locations for the 4 point option

Option #2 – Six Supports

Six supports may be used to support the panel, positioned as shown in Figure 14. At least two supports must be located under each half of the panel, and supports on opposite sides of the panel must be in line with each other.

The first set of supports, installed on either the left or right side of the panel, must be installed between 0 and 15.5 in. from the short-side edge of the panel. The second set of supports should be located at a distance of 24 in. (+/- 1 in.) from the first set of supports and the third set of supports should be located 24 in. (+/- 1 in.) from the second set of supports.

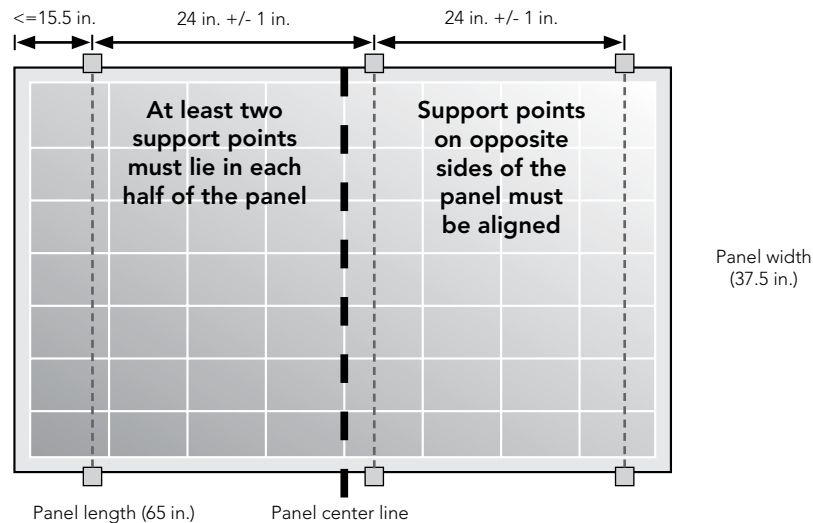

Figure 14:
Required support locations for the 6 point option