

Technical Data Sheet

Model: AB-601
Description: Solar powered ventilation fan; remote mounted PV panel; self-flashing housing; natural finish
Revision: 1
Date: 27-Dec-11
DCN: TDS-1037

Top View

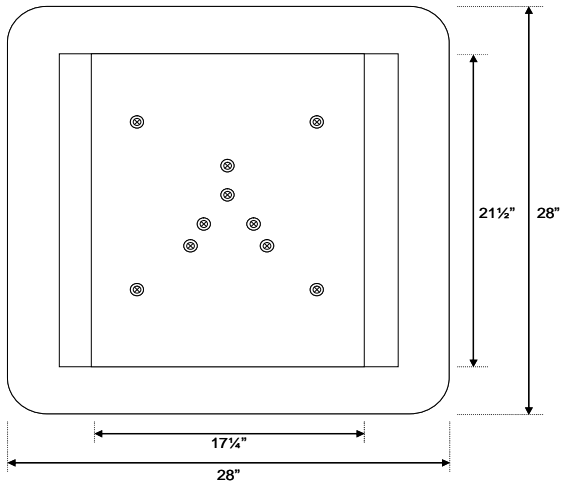

Bottom View

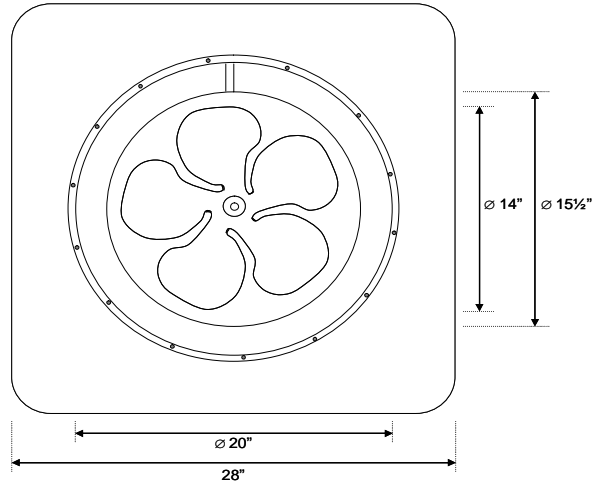

Front View

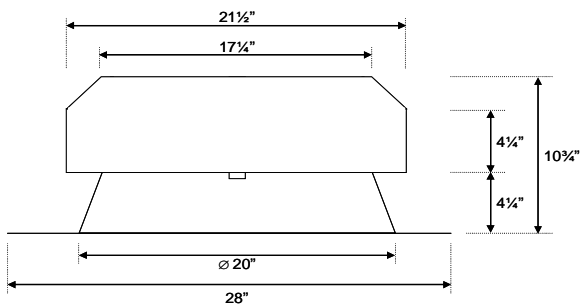

Side View

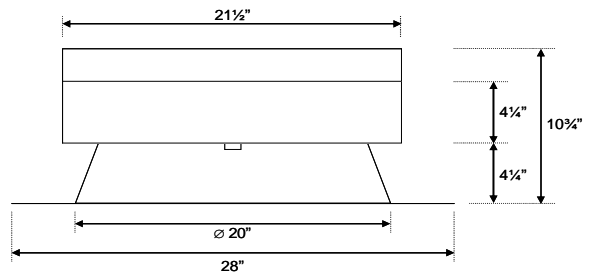

Remote Solar Panel

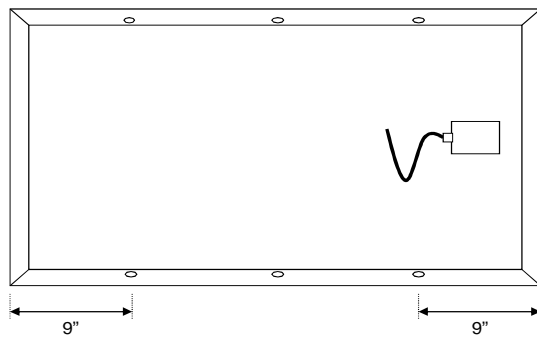
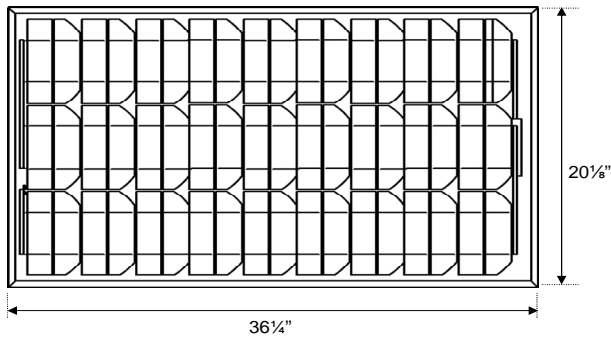

Model AB-601 Specifications

Material of Construction

Fan Housing: 24 GA AZ50 (Zincalume/Galvalume)
Rodent Screen: 1/4" Mesh Stainless Steel Screen
Fan Blade: Proprietary 14" 5-Wing Aluminum Blade with Integrated Balanced Hub
PV Panel: Anodized Aluminum Frame with Impact Resistant Tempered Glass
Finish: Natural Zincalume
Hardware: Stainless Steel Brackets & Fasteners

Electrical

Motor: Proprietary 38V variable speed DC motor
PV Panel: Proprietary 60W monocrystalline solar panel
Internal Wiring: 16 AWG; Wired Ready for Control Options
Remote Cable: SJEOOW (or equivalent) UV/Weather Resistant Cable; 15' x 14AWGX2C
Termination: UV/Weather Resistant Quick Connect Plugs

Performance

Air Movement: 2050 CFM @ 0.0 inH₂O
Noise Level: < 1 sones (< 30 dB)
Wind Rating: +115 PSF/-115 PSF; +170 MPH Wind Speed Equivalence*; Florida Approval #FL13339.2, Florida Approval #FL13339.3 (optional Attic Breeze Universal Bracket System™)

Weight Load

Fan Unit: 22 LBS
Remote Panel: 13 LBS

* Wind speed equivalence based on 30 foot mean roof height in Exposure B; wind zones 1-3; all roof pitches apply

