

UV CLEAR[®] POOL SANITIZER

The Original



2442 23rd Street North
St. Petersburg, FL 33713-4018 USA
1-866-825-0100
www.uvclear.com



CSA/UL Pending



MEMBER



NATIONAL
SPA & POOL
INSTITUTE

OWNER'S MANUAL

5,000 • 15,000 • 25,000 • 50,000

The Ultimate Alternative For A Crystal Clear Pool

UV CLEAR® POOL SANITIZER

The Original

Welcome!

Dear Customer,

Congratulations on the purchase of your new professional UV Clear® Pool Sanitizer for your swimming pool. For over sixty years Ultraviolet light technology has been used as a reliable method of disinfecting process water based on performance and savings. In addition to swimming pool and spa application, UV is also widely used in the food and beverage industry, hospitals, breweries, water treatment plants, drinking water, industrial and municipal wastewater, fish farms, aquaculture, pharmaceutical industries and more.

How Does UV-C Work?

Ultraviolet light is found in the electromagnetic spectrum between visible light and x-ray. The UV spectrum is divided into four bands: UV-A long wave (315-400 nanometers), UV-B medium wave (280-315 nm), UV-C short wave (200-280 nm) and VUV vacuum UV (100-200 nm). The UV-C wavelength has a strong "germicidal" effect on microorganisms that cause bonds to be broken known as Photochemistry. UV Clear® Systems inactivates bacteria, viruses and eliminates floating algae through absorption of UV-C. At 254 nanometers, the light energy penetrates the cell wall of microorganisms and disrupts the DNA chain so that cells cannot replicate. A cell that cannot replicate is considered dead.

UV Clear® Systems Provides:

- Reliable disinfection that eliminates biological growth
- Reduction of residual sanitizer
- Simplicity in design for easy installation and low maintenance
- Safety for swimmers and the environment
- No skin and eye irritation
- A system that does not impart any taste or odor
- No UV overdosing

Enjoy swimming in a clean, clear, fresh smelling pool with UV Clear® Pool Sanitizer that offers a more natural pleasant environment by reducing the overall usage of chemicals.

Your UV Clear® Pool Sanitizer is suitable for use in all residential swimming pools up to the size recommended on the package. Make sure to maintain proper pool water balance for maximum UV performance and sanitizer reduction. For more information about pool maintenance and water balance, call 1-800-548-NSPI (6774) or visit www.nspi.org.

Warranty

This product is warranted for 2 years from the date of purchase against any faults due to workmanship. The bulb and the quartz glass sleeve are not warranted against breakage. Warranty claims can be handled only if the product is returned with an authorized RMA number provided with dated receipt of purchase. The manufacturer does not offer warranty claims caused by installation or servicing faults. In addition, defects stemming from improper maintenance are also not warranted. The manufacturer is not liable for damage caused by misuse of the product. The manufacturer disclaims any obligations or liability for loss of use of the product warranted, loss of time, inconvenience or any other direct, consequential, special or incidental damages. Contact dealer for warranty claims.

IMPORTANT SAFETY INSTRUCTIONS

WARNING - To guard against injury, basic safety precautions should be observed, including the following:

READ AND FOLLOW ALL SAFETY INSTRUCTIONS.

CAUTION - To prevent risk of electric shock, disconnect power before servicing or replacing bulb. To avoid possible electric shock special care should be taken since water is employed in the use of this equipment. For each of the following situations, do not attempt repairs yourself; return the appliance to an authorized service facility for service or discard the appliance.

CAUTION - To prevent corrosion or deterioration of materials that could lead to electric shock, use only with fresh water.

CAUTION - Be sure to disconnect power prior to maintenance. This device produces Ultraviolet rays. Never touch or look directly at the bulb while it is on.

This device must be cleaned once a year. The deposits from the dead algae and minerals may have a tendency to build up on the quartz glass sleeve (E) that shields the bulb (C). The bulb (C) needs to be replaced at 9,000 hours. If the device is on continuously, the bulb needs to be replaced in approximately 1 year. (Please refer to diagram 1, for parts.)

CAUTION - To prevent possible fire or electric shock, use bulb rated 16 watt, 40 watt or High-Output 40 watt, Philips ultraviolet type T5, single ended, 4-pin, according to model used.

- A. If the appliance falls into the water, DON'T reach for it! First disconnect power and then retrieve it. If electrical components of the appliance get wet, disconnect power to the appliance immediately. DO NOT immerse in water.
- B. Do not operate any appliance if it has a damaged cord or plug, or if is malfunctioning or if it is dropped or damaged in any manner.

Always disconnect an appliance from an outlet when not in use, before putting on or taking off parts, and before cleaning. In case installed with plug, never yank the cord to pull the plug from the outlet. Grasp the plug and pull to disconnect.

Do not use an appliance for other than its intended use. The use of attachments not recommended or sold by the appliance manufacturer may cause an unsafe condition.

Read and observe all the important notices on the appliance.

"SAVE THESE INSTRUCTIONS"

UV CLEAR POOL SANITIZER

The Original

Installation Instructions (Please refer to diagram 1) 5,000, 15,000, 25,000, 50,000

Never submerge this device in water. Always install the unit outside of the pool where the pool equipment pad is located.

CAUTION – The UV bulb produces ultraviolet radiation and direct contact may be harmful to eyes and skin. Therefore do not open the unit during operation.

1. Turn the power off. Install the UV unit on the return line after the filter and before heater, feeder and/or generator. Plan the plumbing for a closed loop by-pass preferably.
2. Use a 3-way valve (See Example: By-Pass) to regulate the flow entering the UV unit.
3. Select a location on the wall to secure the mounting brackets in a vertical position.
4. Make sure to leave enough space above the unit (40" min.) for servicing. Be sure that the mounting brackets (G) are positioned between the black band and the inlet/outlet of the chamber. Fasten the brackets to hold the unit in place.
5. Install PVC pipe (B) from the 3-way valve to the inlet of the unit. Hand-tighten the union fitting (A) to the threaded inlet.
6. Before routing pipe from the 3-way valve and the chamber's outlet to join together with a tee on the return line, add a ball valve to the outlet side of the return line to complete the closed loop by-pass. If necessary, the UV unit can now be disconnected for servicing. Hand-tighten the union fitting onto the unit's threaded outlet.
7. Carefully align the quartz glass sleeve (E) into the sleeve holder (I) -[see diagram 3] inside the chamber and slide the quartz glass sleeve until the sleeve is properly seated in the chamber.
8. Connect the bulb (C) into the bulb holder (D) found inside the cap (F).
9. Hand-tighten the cap (F) onto the chamber.
10. For 120 Volt models, a molded plug comes standard. Plug into a GFCI plug outlet.
11. Terminal ends are standard on 240 volt models. Consult an electrician qualified in swimming pool, hot tub and spa equipment installation. GFCI's can be installed in a circuit breaker panelboard or directly in a receptacle outlet.
12. Turn power on and check water flow and bulb operation through the inlet and outlet. Check for any leaks. Reset the correct time on the clock.

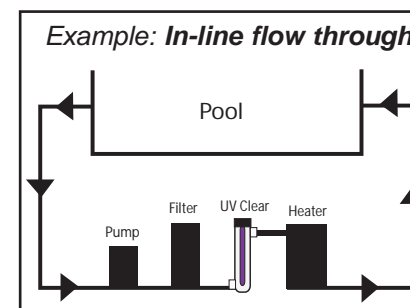
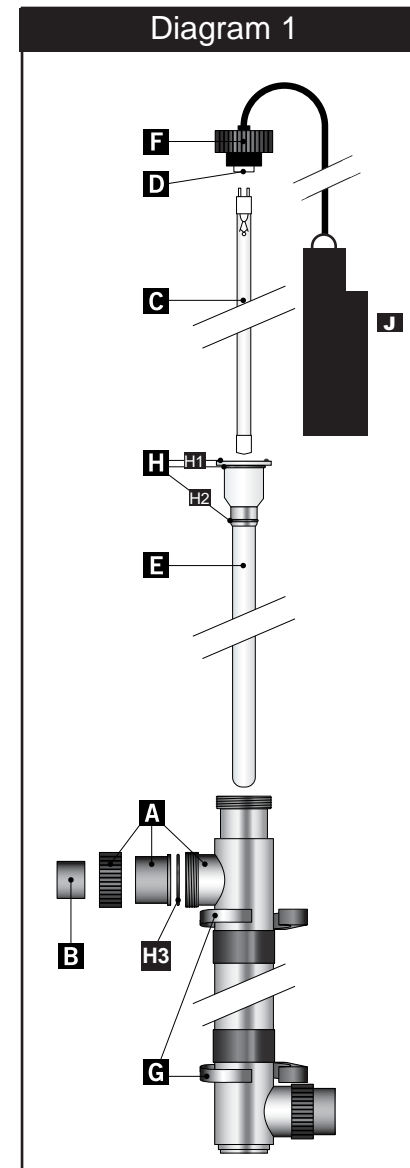

PARTS LIST KEY	
A. Union Fitting	G. Mounting Bracket
B. PVC Pipe/Bushing	H1. Medium O-ring
C. Bulb	H2. Small O-ring
D. Bulb Holder	H3. Large O-ring
E. Quartz Glass Sleeve	I. Sleeve Holder
F. Cap	J. Ballast

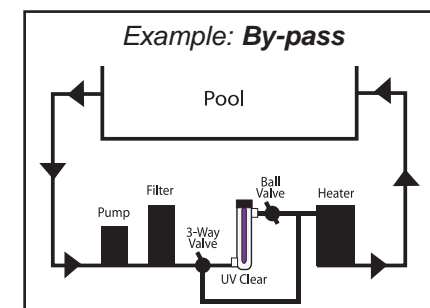
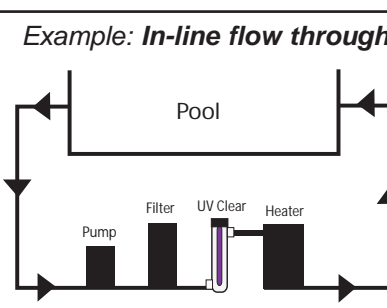
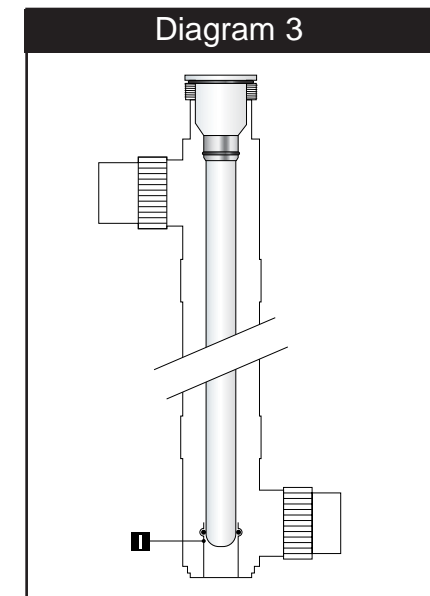
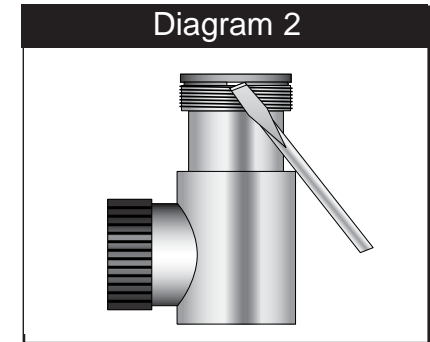

ENGLISH

UV CLEAR POOL SANITIZER

The Original

Grounding

Install Ground Fault Circuit Interrupters (GFCI) in accordance with applicable local codes and the NEC. To prevent electrocution follow instructions accompanying the GFCI device. If you are uncertain or confused about how to install a GFCI device, consult a licensed electrician for the installation of appropriate Ground Fault Circuit Interrupter (GFCI).

WARNING - This product is not submersible. If any parts are damaged do not use this product. Never submerge this device in water. Always install the unit under or on the outside of spas and the proper distance away from pools.

Maintenance

CAUTION - Be sure to disconnect power prior to maintenance. This device produces Ultraviolet rays. Never touch or look directly at the bulb while it is on. To prevent risk of electric shock, pull plug or disconnect power before servicing or replacing bulb.

The quartz glass sleeve (E) must be cleaned once a year. The deposits from the dead algae or minerals may have a tendency to build up on the quartz glass sleeve (E) that shields the bulb (C). The bulb (C) needs to be replaced at 9,000 hours. If the device remains on continuously, the bulb (C) needs to be replaced in approximately 1 year. If the bulb runs an average of 8 to 12 hours daily, then the bulb must be replaced in approximately 2 years. Contact your dealer for replacement bulb. Replace with original manufacturer's equipment bulb.

1. Turn the power off.
2. Unscrew the cap (F) and disconnect the bulb(C) from the bulb holder (D). Replace the bulb if necessary. Useful bulb life is 9,000 hours.
3. Do not touch bulb (C) may be hot. Use a clean soft cloth to handle the bulb.
4. Carefully pry the quartz glass sleeve (E) off with a coin, or a flat-head screwdriver (See Diagram 2). Do not use excessive force!
5. Clean the quartz glass sleeve (E) with a non-abrasive cleaning solution, such as rubbing alcohol or glass cleaner with a clean soft cloth to prevent scratching the surface. Rinse thoroughly. Only clean the outer surface of the quartz glass sleeve (E).
6. Before inserting the quartz glass sleeve (E) make sure that the o-rings (H) are correctly in place.
7. Carefully align the quartz glass sleeve (E) into the sleeve holder (I) [See diagram 3]. Standing over the unit, you can see the sleeve holder (I) on the bottom of the chamber through the quartz glass sleeve. Slide the quartz glass sleeve (E) until it is properly seated onto the top of the chamber. There should not be a gap between the top of the chamber and the sleeve.
8. Use a soft clean cloth to hold the bulb (C) and connect to bulb holder (D).
9. Hand-tighten the cap (F).
10. Turn the power on and check for water flow, bulb check and for leaks.

Technical Specifications

Model	5,000	15,000	25,000	50,000
240 V / 60 Hz Ballast		✓	✓	✓
120V / 60 Hz Ballast	✓	✓	✓	✓
Lamp Wattage	16 Watt	40 Watt	75 Watt	2 x 75 Watt
UV-C Output*	3.9 Watt	15 Watt	25 Watt	2 x 25 Watt
UV-C (%) after 9,000 Hours	75%	85%	80%	80%
Max. Gallons**	5,000	15,000	25,000	50,000
Max Pressure	120 Psi	120 Psi	120 Psi	120 Psi
L" x W"	19" x 5"	40" x 5"	40" x 5"	40" x 10"
Flow Rate per Hour	1,000 gph	2,400 gph	4,000 gph	5,300 gph
Amperage for 120V & 220V	0.41A	0.47A	1.0A	2 x 1.0A
Useful Lamp Life (Hours)	9,000	9,000	9,000	9,000
Fittings	2" Union	2" Union	2" Union	2" Union
Bushing/Reducer	✓	✓	✓	✓

Customizing A System For Your Pool

In cases where the pool does not match or exceeds the recommended maximum gallons, multiple units can be installed in series. Any 2 units can be fitted together as long as they are the same voltage. For example, Two 15,000 units can treat up to a 30,000 gallon pool or combine a 15,000 with a 25,000 to treat a 40,000 gallon pool. To connect multiple units in series, use a 2.25 inch length of PVC pipe. (See Diagram 4 below)

