

# Flat Model Installation Sheet

Model #FB7266

- 1.) Cut a 14 1/2" diameter hole between rafters approximately 24" down from roof peak to center of hole.
- 2.) Trim away top rows of shingles an additional 2" to allow base flashing to slip under top rows of shingles and over bottom rows.
- 3.) Slip the flat base under the top rows of shingles and center unit over opening with the SRS Logo on the bottom.
- 4.) Gently lift the unit and apply sealant under lower edge and sides of base flashing.
- 5.) Pre-drill (4) mounting holes along the bottom edge of the base flashing, and (1) hole on each side approximately 3" up from the bottom edge.
- 6.) Using stainless steel screws, secure unit to roof deck.

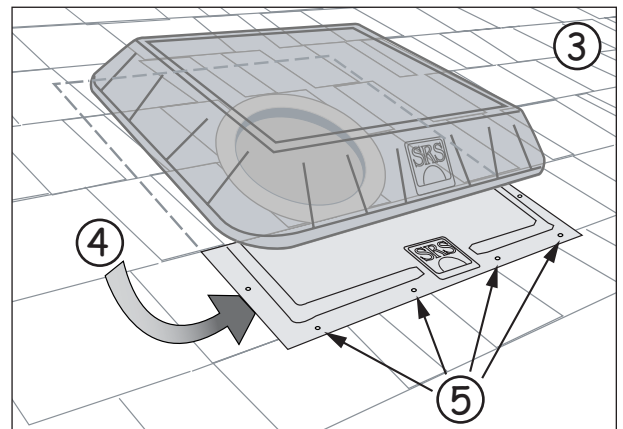
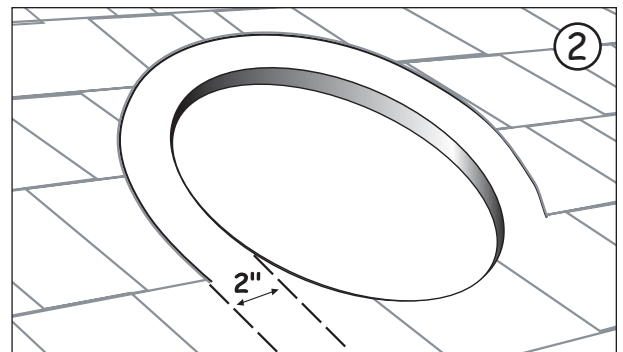
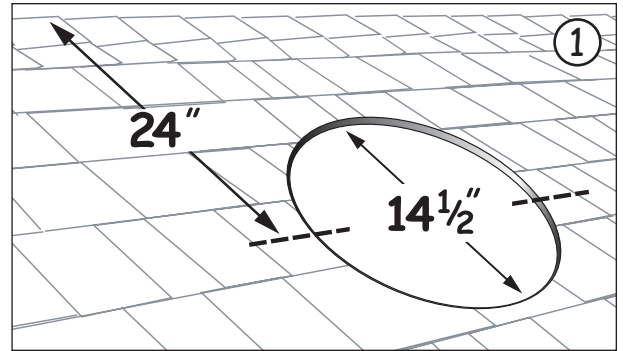

DO NOT OVER-TIGHTEN SCREWS, AS THIS MAY CAUSE  
UNIT BASE TO CRACK OVER TIME.

