

## Just one SunRise™ is powerful enough to protect an entire home

With its 12" aluminum fan, SunRise™ circulates up to 850 cubic feet of air per minute, providing enough protection for a 1,200 square foot attic! SunRise™ uses an advanced, Tefzel-coated solar panel to collect and deliver power directly from the sun to a highly efficient 12-volt DC motor. This non-breakable panel collects solar energy even in reduced light and poor weather conditions and provides maximum cooling effect when it's needed most--in the middle of the day. It operates without fuel, waste, or pollution and is wind, hail, and impact resistant. The SunRise™ comes fully assembled and can be installed in under an hour. It requires no electrical hook-up.

### Positive Results

*"I highly recommend this product. We are the leading supplier of solar attic fans in Hawaii, and over the years we've sold thousands... The makers of SUNRISE solar fans have raised the bar as the best non-corrosive unit available."*

— Cully Judd, CEO Inter-Island Solar Supply, Hawaii

*"The advanced technology and dynamic range of the SUNRISE solar panel allows the integrated and efficient motor to provide maximum airflow during daytime hours, even when the skies are overcast."*

— Tony DePirro, B.S. Electrical Engineering Technology, Purdue University

*"My company installed a competitive solar vent system for several years. The weaknesses were obvious, so I decided to build a better vent based on my experience. We spared no expense developing the SUNRISE solar powered attic fan. From the latest solar powered technology, to the most installer friendly design, the SUNRISE is the only choice."*

— Bill Keith, President SunRise Solar Inc.



For more information please contact:

SunRise Solar Inc.  
P.O. Box 53 St. John, IN 46373  
Phone/Fax: 219-558-2211  
Email [bill@sunrisesolar.net](mailto:bill@sunrisesolar.net)  
or visit [www.sunrisesolar.net](http://www.sunrisesolar.net)

5 year warranty on motor.  
Solar panel and all other parts are 10 years.  
Patent pending  
Made in the USA



# Let the sun cool your home!

Introducing—  
*The SunRise™*  
Solar-powered Attic Fan

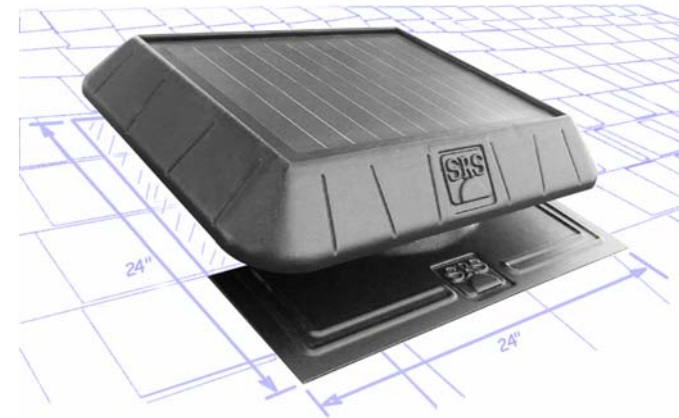

*An environmentally friendly*

low cost  
— then no-cost —  
way to cool and protect  
your attic and roof

# Heat and moisture are your attics worst enemy

## On hot days—

The temperature in your attic can exceed 150°. Small, passive roof vents are often woefully inadequate at dissipating this heat. The attic acts like a giant radiator, passing excess heat back into your living spaces and driving temperatures and cooling costs through the roof.

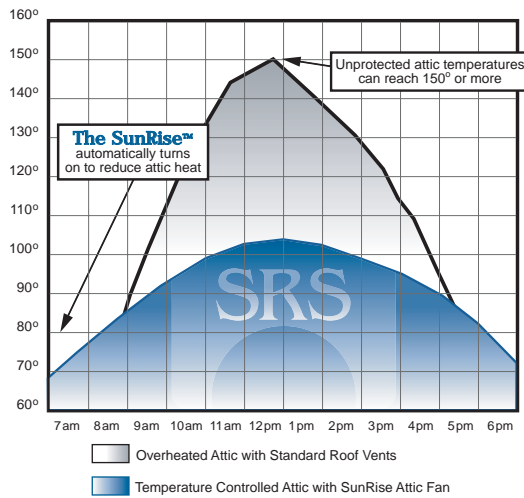

## Northern cold winter months—

The heat trapped in your attic can melt the snow that accumulates on your roof. As the water trickles down, it refreezes at the cooler eaves, leading to destructive and costly ice damming.

## Saving the environment—

Because the SunRise™ uses sunlight to generate *it's own electricity*:

- It is an unlimited renewable energy source
- No fossil fuels are burned
- No pollution is created

## The SunRise™ solar-powered attic fan will save you money on cooling costs

The SunRise™ is a unique, solar-powered vent fan that pulls the heat right out of your attic. This means less heat dissipating back into your living area, less drain on your air conditioning system, and less cost to you.

In fact, up to 30% less money spent on air conditioning costs alone!

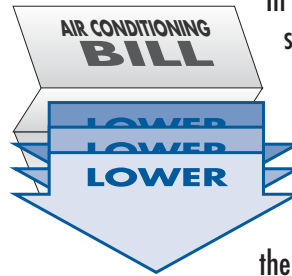

In the wintertime, the SunRise™ helps equalize the air temperature between the inside and outside of your attic.

This dramatically reduces the risk of ice dams forming at the eaves--a feature that could save you thousands.

## Reduces moisture build-up and prolongs the life of your roof

Even in newer homes that use vapor barriers, moisture can still sneak into the attic and condense on framing boards, roof decking, and insulation. The problem may be even worse in older homes that have settled and developed cracks or air leaks around bathroom exhaust fans or light fixtures. SunRise™ forcibly expels this warm, moist air, helping prevent the growth of mold and mildew, and significantly reducing the chance of rotting the roofing materials.



**All without costing you a penny to operate!**

## Flat Model #FB7266

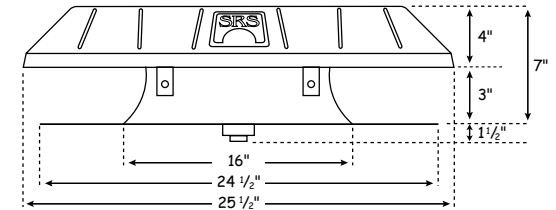

## Curb Model #CB7266

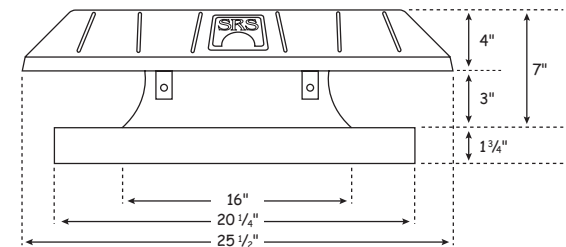

- Solar Panel:** 11 Watts, multiple-stacked cell, flexible and non-breakable, shade and shadow tolerant.
- Motor:** 1–38volt DC with external brushes.
- Wire:** Proprietary 18/2 red/black.
- Fan Blade:** 12" diameter, 5-blade aluminum with balanced hub.
- Hardware:** Stainless steel motor brackets, fasteners, and screen. Aluminum rivets.
- Top and Base:** UV-Stabilized ABS plastic with acrylic cap (paintable).
- Airflow:** 850 Cubic Feet per Minute (CFM) in full sunlight.
- Unit Dimensions:** Height 7", Top 25.5" x 21.25", Flat Base: 24.5" x 24.5", Curb Base: 20.25" x 20.25".
- Unit Weight:** 15 lbs.
- Package Size:** 27.25" x 25.5" x 11.25" wide.
- Shipping Weight:** 16 lbs.